
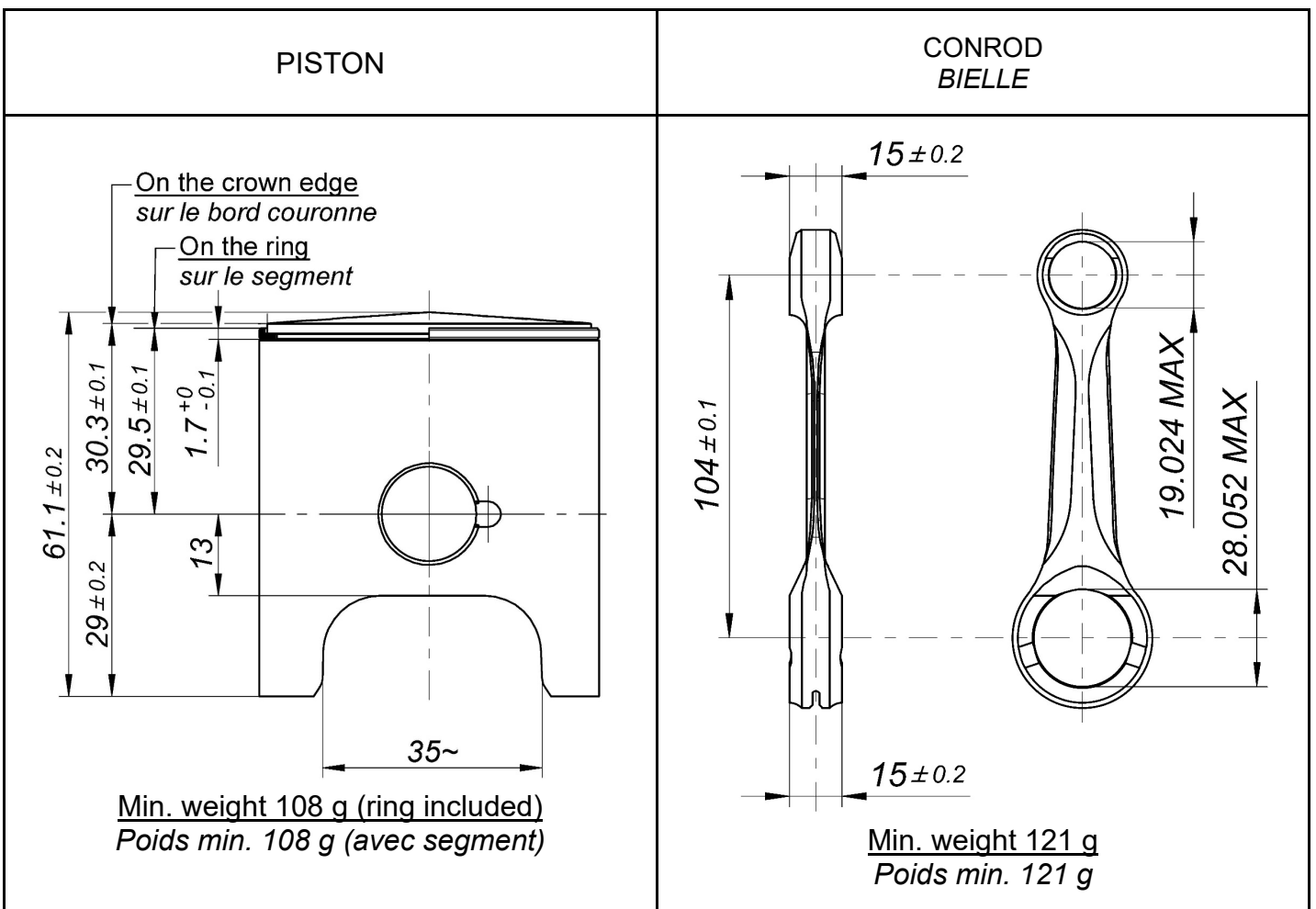


# S125 RL - C TAG

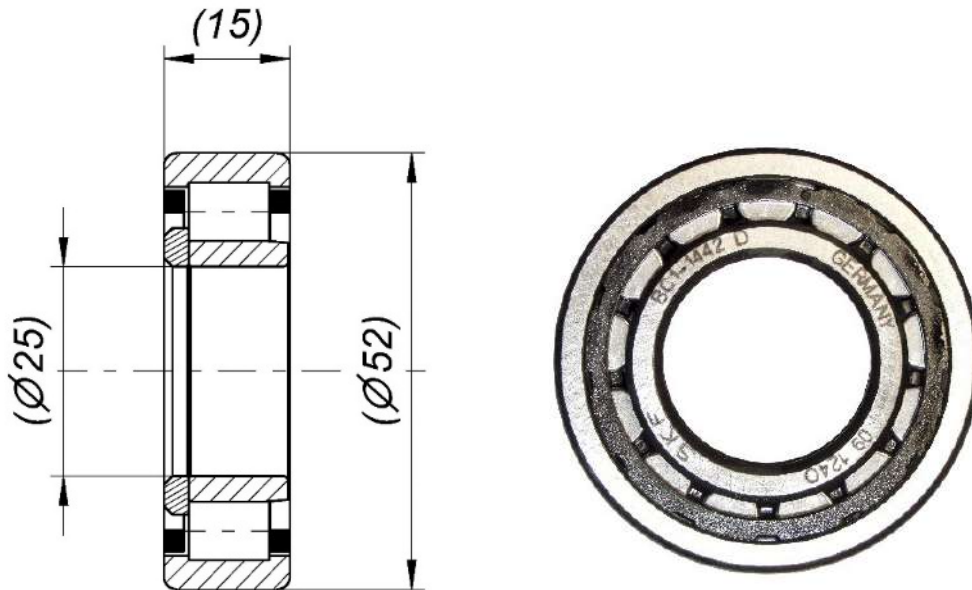
		<b>FEATURES - CARACTERISTIQUES</b>	
		Cylinder volume <i>Volume du cylindre</i>	124.08 cm <sup>3</sup>
		Bore <i>Alésage</i>	53.89 mm
		Max. bore <i>Alésage max.</i>	54.08 mm
		Stroke <i>Course</i>	54.4 mm
		Cooling system <i>Système de refroidissement</i>	Water <i>À Eau</i>
		Inlet system <i>Système d'admission</i>	Reed valve <i>À clapets</i>
		Cylinder / crankcase transfers n° <i>N° de canaux cylindre / carter</i>	5 / 3
Carburettor Tillotson <i>Carburateur Tillotson</i>	HW-50A (Ø24 Venturi)	Inlet / exhaust ports number <i>N° lumières admiss. / échapp.</i>	5 / 3
Number of piston rings <i>Nombre de segments</i>	1	Combustion chamber shape <i>Forme chambre de combustion</i>	Spherical <i>Sphérique</i>
Big end conr. bearing diam. <i>Diamètre roulement tête de bielle</i>	22x28x15	Ignition <i>Allumage</i>	Digital
Crankshaft bearing diam. <i>Diamètre roulement du vilebrequin</i>	25x52x15	Distance between conrod centers <i>Longueur (entraxe) de la bielle</i>	104 mm
Small end conr. bearing diam. <i>Diamètre roulement pied de bielle</i>	15x19x20	RPM limiter <i>Limiteur de régime</i>	Yes <i>Oui</i>
Balancing shaft <i>Arbre d'équilibrage</i>	Yes <i>Oui</i>	Electric starter <i>Démarrreur électrique</i>	Yes <i>Oui</i>

DESCRIPTION OF THE MATERIAL - *DESCRIPTION DES MATERIAUX*

Conrod material <i>Matériau de la bielle</i>	Steel <i>Acier</i>	Liner material <i>Matériau de la chemise</i>	Iron <i>Fonte</i>
Crankshaft material <i>Matériau du vilebrequin</i>	Steel <i>Acier</i>	Crankcase material <i>Matériau du carter</i>	Aluminium
Balancing shaft material <i>Matériau de l'arbre d'équilibrage</i>	Steel <i>Acier</i>	Piston material <i>Matériau du piston</i>	Aluminium
Gears material <i>Matériau des engrenages</i>	Steel <i>Acier</i>	Piston rings material <i>Matériau des segments</i>	Iron <i>Fonte</i>
Starter ring material <i>Matériau de la couronne démarreur</i>	Steel <i>Acier</i>	Exhaust muffler material <i>Matériau du pot d'échappement</i>	Sheet-steel <i>Tôle acier</i>
Head material <i>Matériau de la culasse</i>	Aluminium	Roller bearings <i>Roulements à rouleaux</i>	BC1-1442D
Cylinder material <i>Matériau du cylindre</i>	Aluminium		

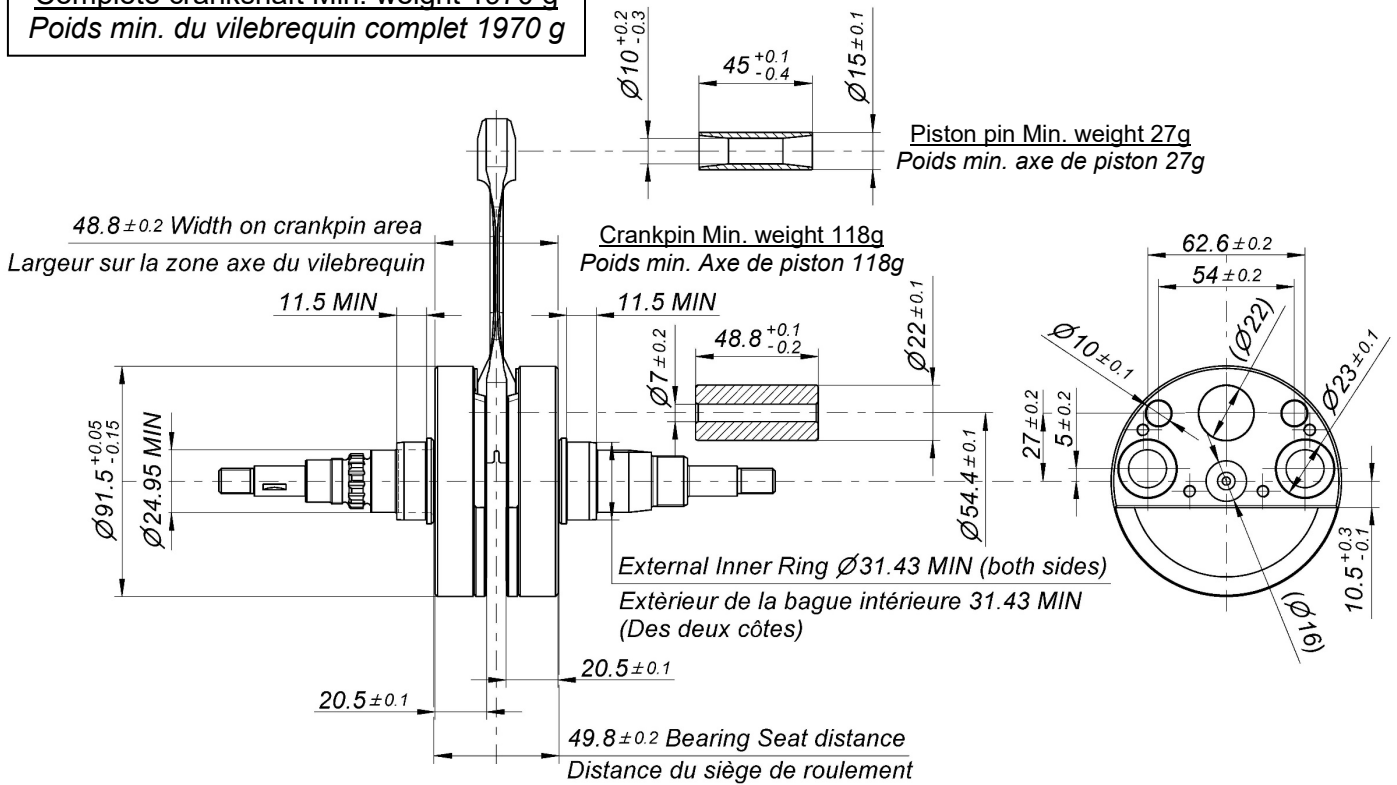


# CRANKSHAFT ROLLER BEARINGS - ROUEMENTS À ROULEAUX DU VILEBREQUIN

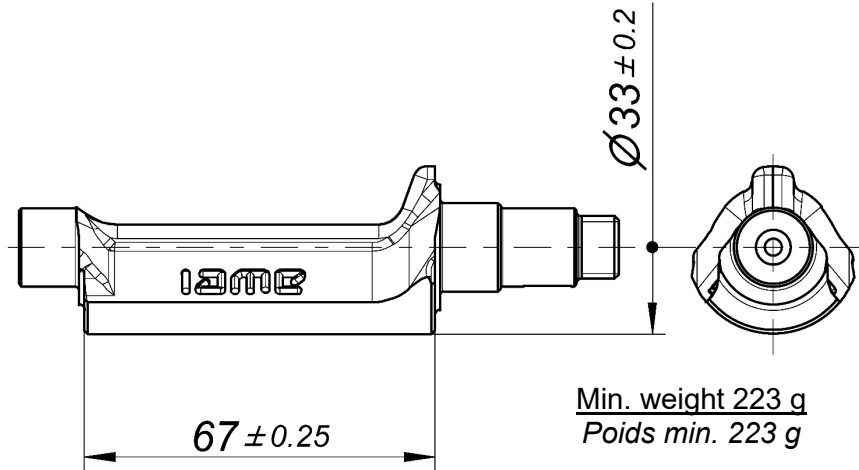


## DIMENSIONS OF CRANKSHAFT DIMENSIONS DU VILEBREQUIN

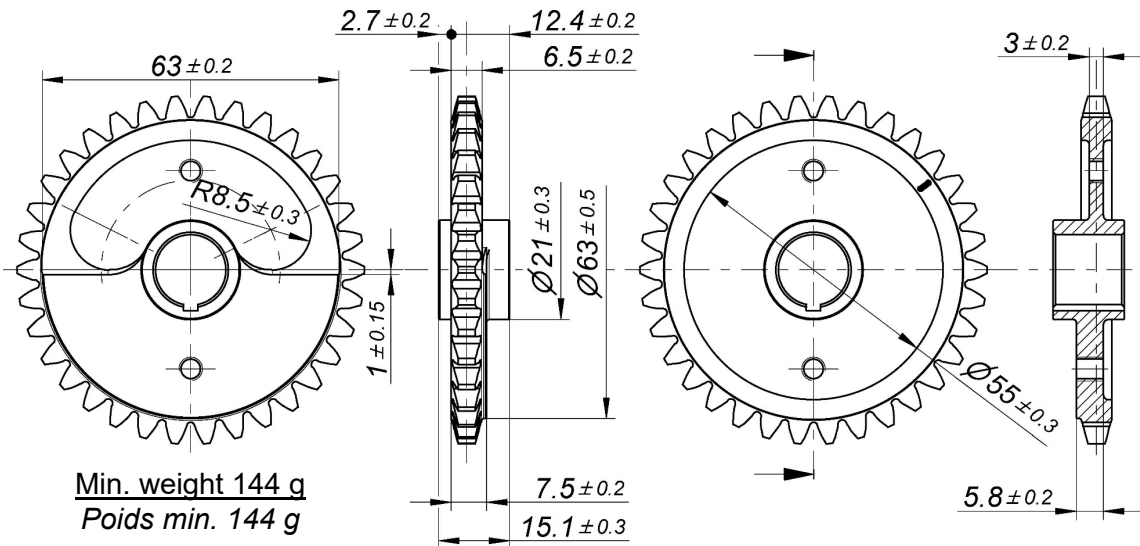
Complete crankshaft Min. weight 1970 g  
Poids min. du vilebrequin complet 1970 g



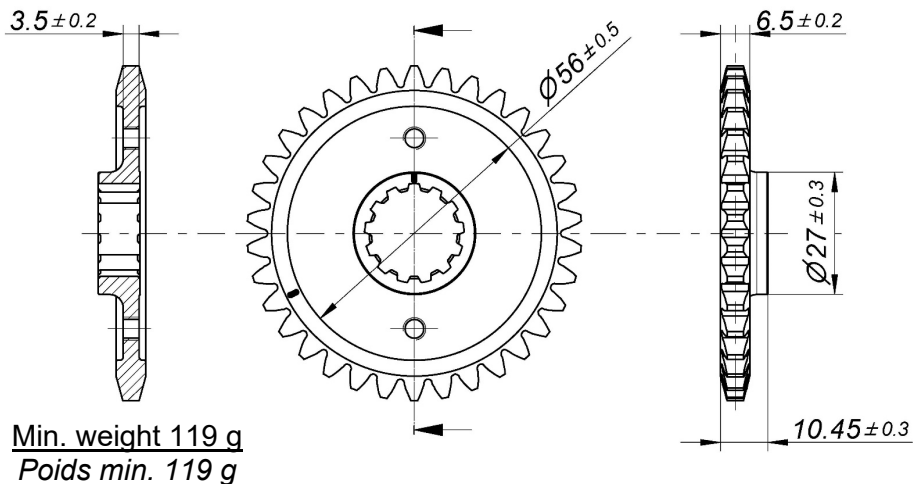
BALANCER SHAFT - ARBRE D'EQUILIBRAGE



BALANCER SHAFT GEAR - ENGRENAGE ARBRE D'EQUILIBRAGE

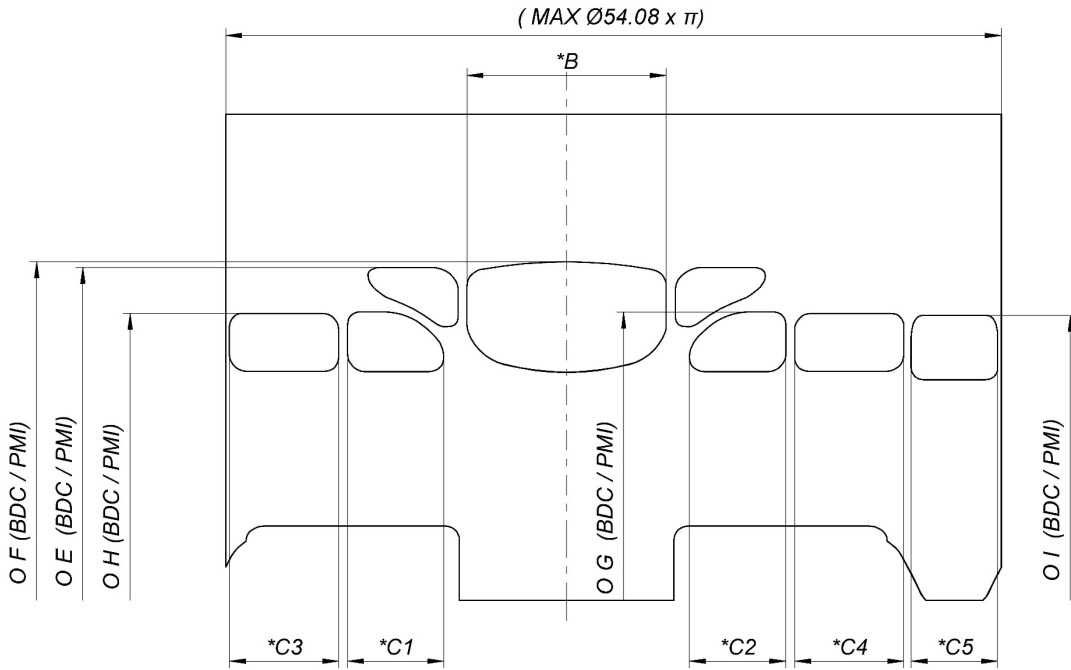


CRANKSHAFT GEAR - ENGRENAGE DU VILEBREQUIN





# CYLINDER DEVELOPMENT - DEVELOPPEMENT DU CYLINDRE

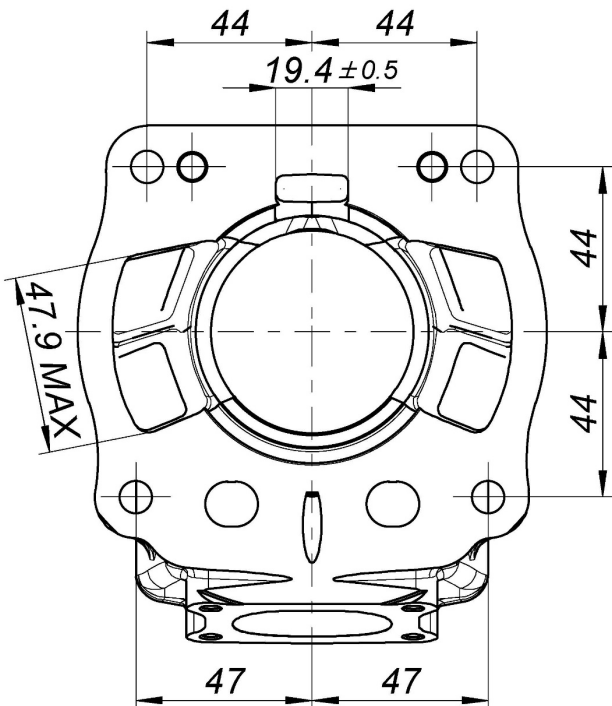


<b>B</b>	≤ 38.5 mm
<b>C1 = C2</b>	≤ 21.0 mm
<b>C3 = C4</b>	≤ 23.7 mm
<b>C5</b>	≤ 19.0 mm
<b>E</b>	174.0° ±1.5°
<b>F</b>	179.5° ±1.5°
<b>G</b>	129.0° ±1.5°
<b>H</b>	127.5° ±1.5°
<b>I</b>	125.0° ±1.5°

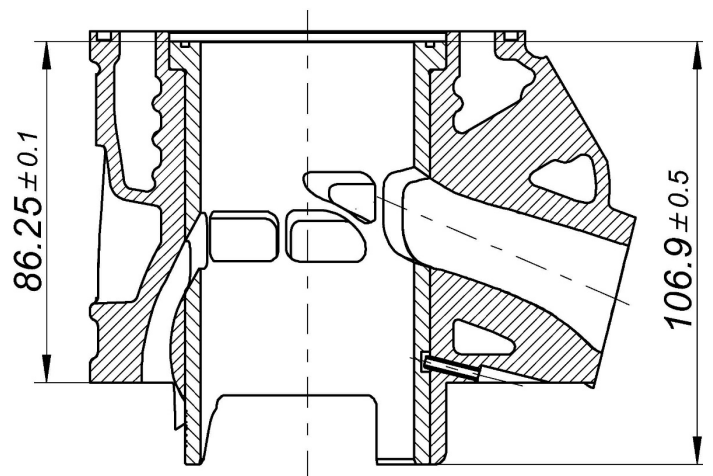
\* CHORDAL READING - LECTURE CORDALE

○ ANGULAR READING BY INSERTING A 0.2x5 mm GAUGE  
LECTURE ANGULAIRE PAR INSERTION D'UNE CALE DE 0.2x5 mm

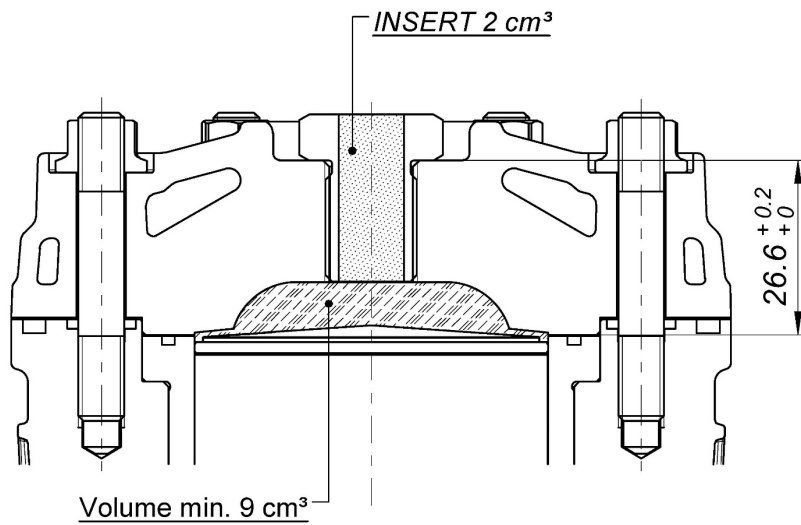
CYLINDER BASE VIEW  
VUE DE LA BASE DU CYLINDRE



CYLINDER CROSS SECTION VIEW  
VUE EN SECTION DU CYLINDRE



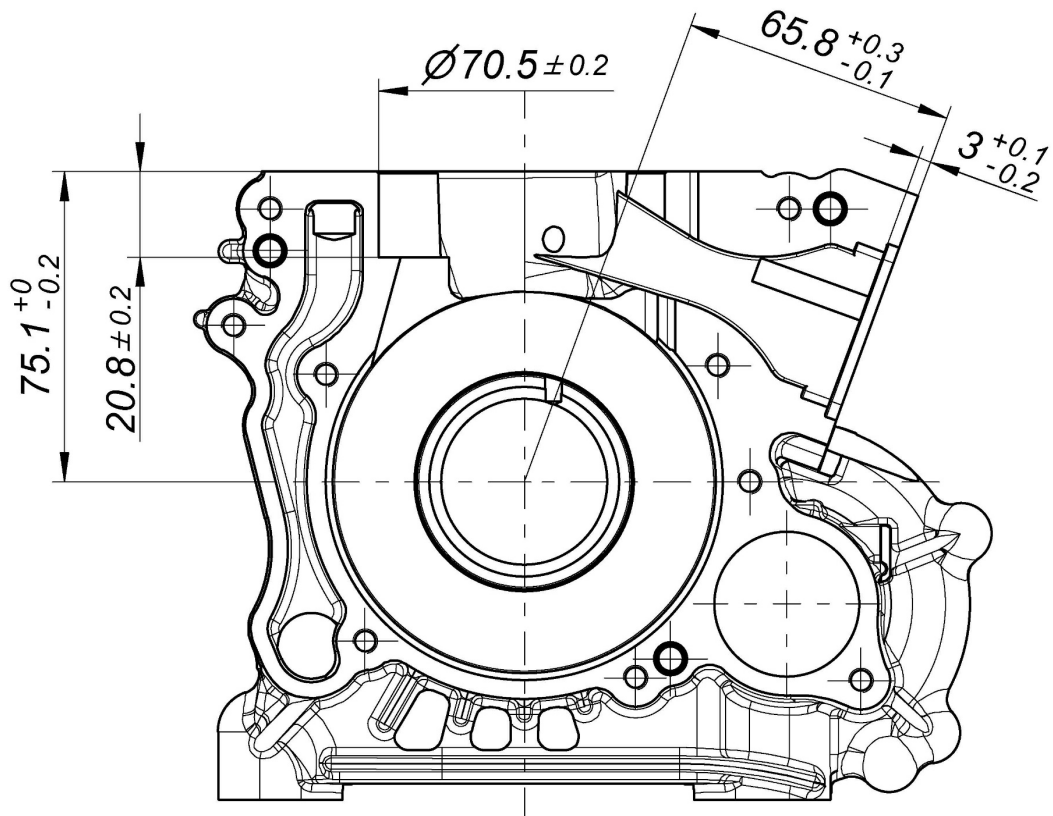
COMBUSTION CHAMBER SECTION  
SECTION DE LA CHAMBRE DE COMBUSTION



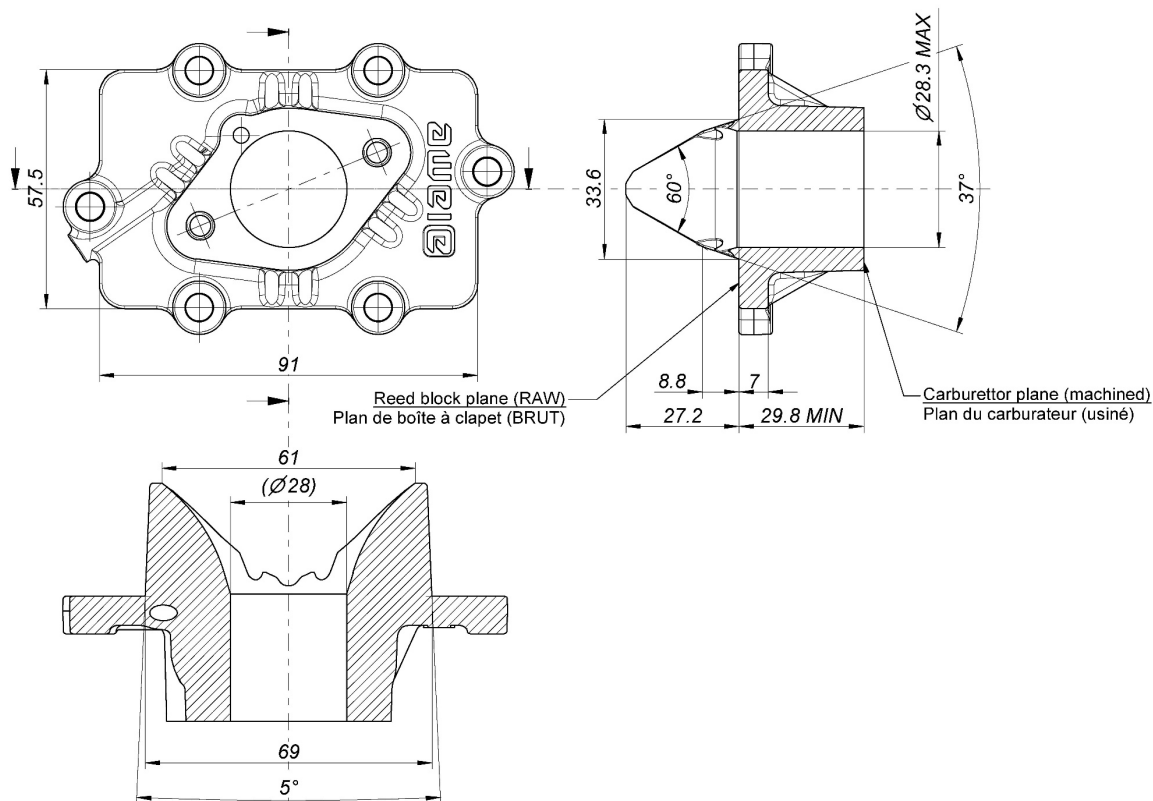
COMBUSTION CHAMBER VOLUME TOT. = 11.0 cm<sup>3</sup> min.  
VOLUME CHAMBRE COMBUSTION TOT. = 11.0 cm<sup>3</sup> min.

ATT. : SQUISH MIN. = 0.85 mm  
(measured with Ø1.5-1.6 mm TIN - mesurée avec de l'étain Ø1.5-1.6 mm)

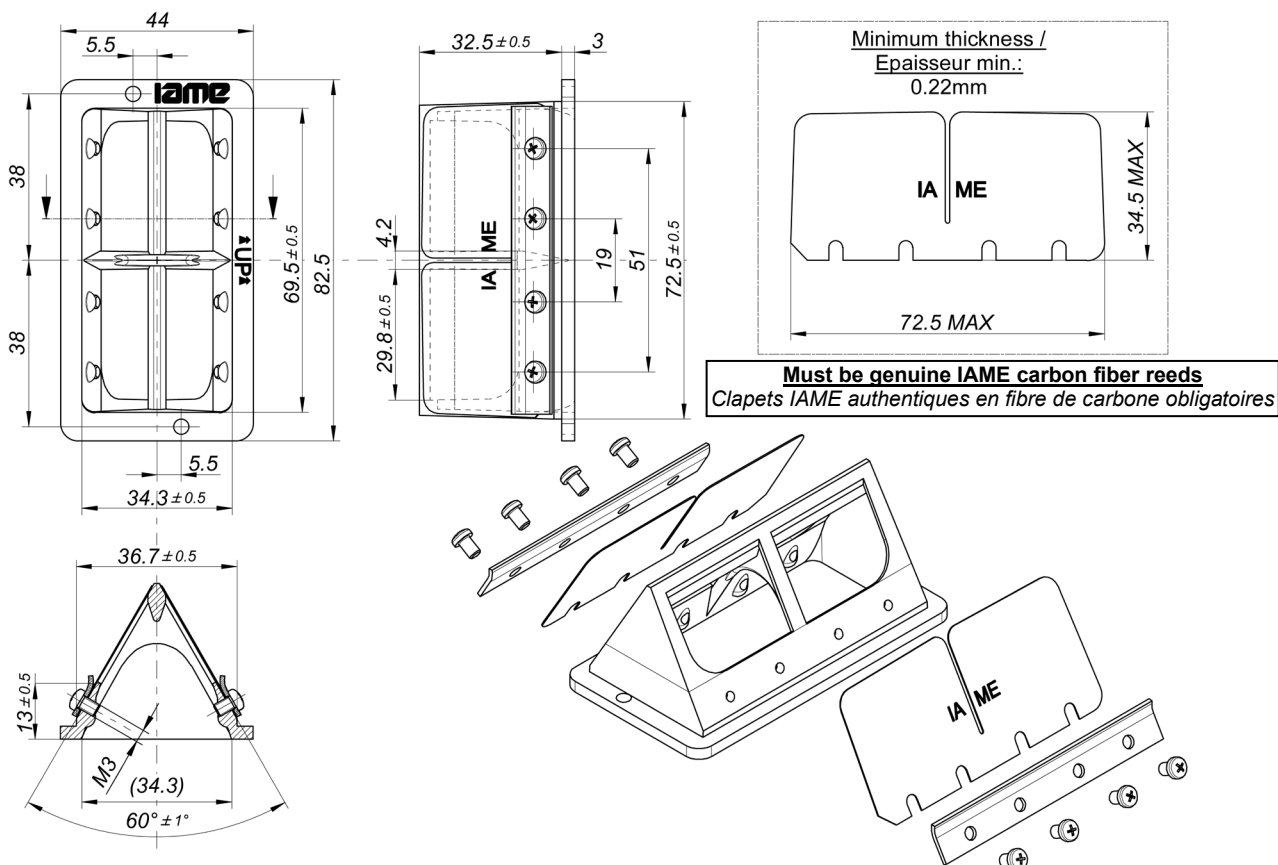
CRANKCASE INSIDE VIEW  
VUE A' L'INTERIEUR DU CARTER



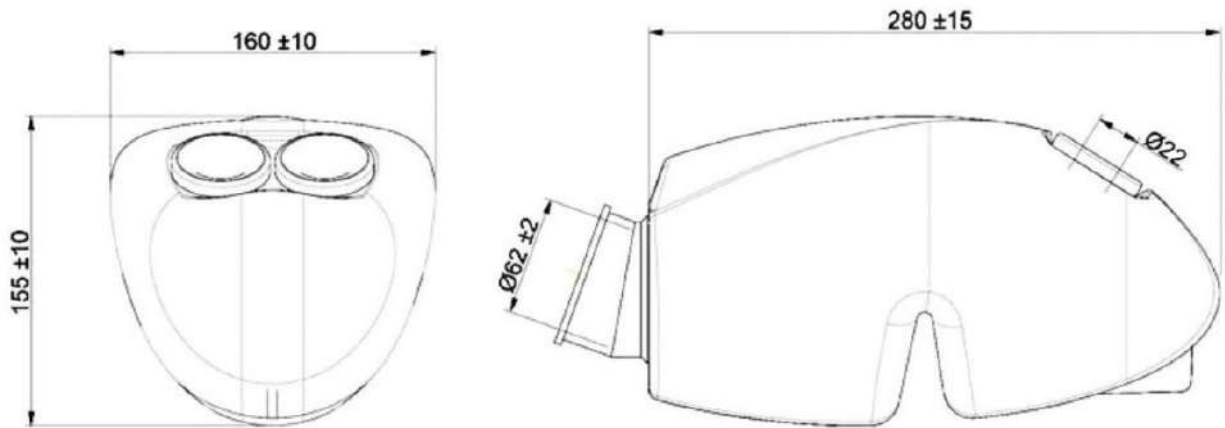
**INLET CONVEYOR - DIMENSIONS AND MARKING**  
**CONVOYEUR D'ADMISSION - DIMENSIONS ET MARQUAGE**



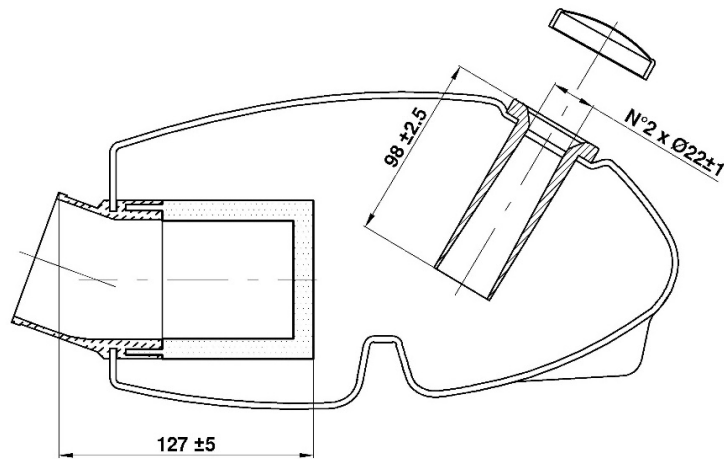
**REED VALVE - DIMENSIONS AND MARKING**  
**BOÎTE À CLAPETS - DIMENSIONS ET MARQUAGE**



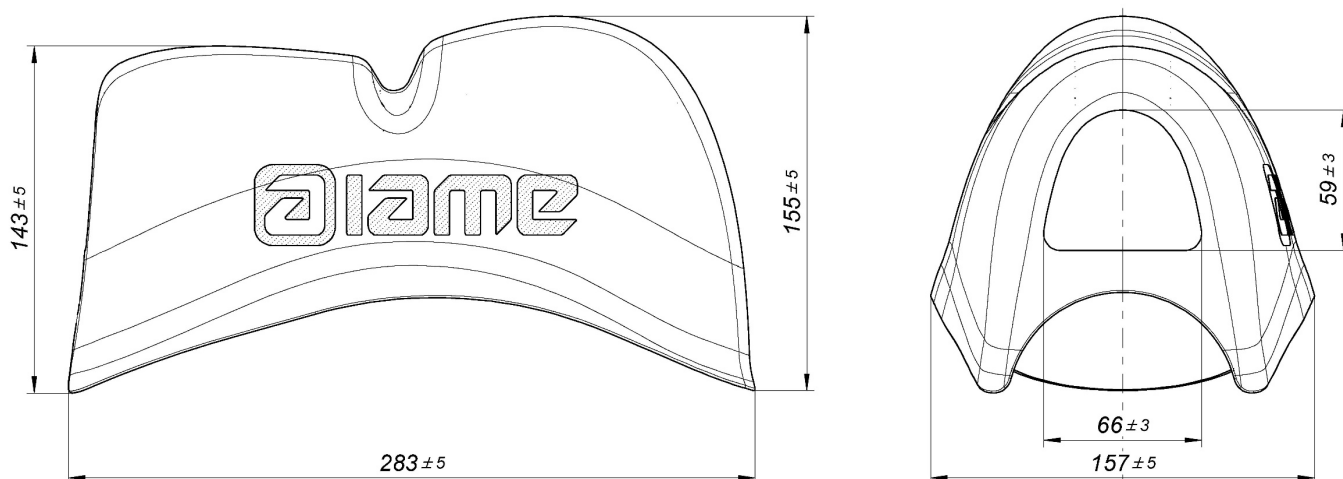
INTAKE SILENCER – DIMENSIONS AND PHOTO  
DESSIN ET PHOTO DU SILENCIEUX D'ADMISSION



WITH SPONGE AIR FILTER  
AVEC MANCHON COMPLET ET FILTRE À AIR



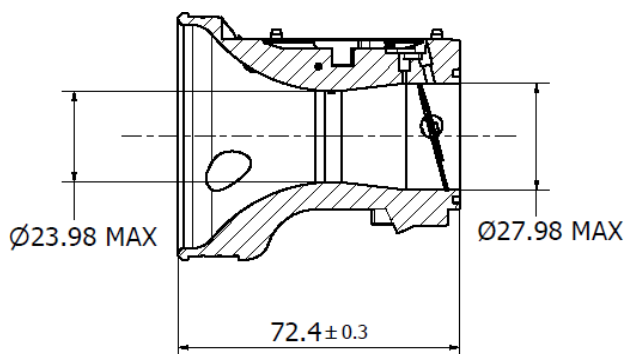
RAIN COVER FOR INTAKE SILENCER – DRAWING  
 DESSIN DU COUVERCLE « PLUIE » DU SILENCIEUX D'ADMISSION



RAIN COVER FOR INTAKE SILENCER – PHOTO  
 PHOTO – COUVERCLE « PLUIE » DU SILENCIEUX D'ADMISSION

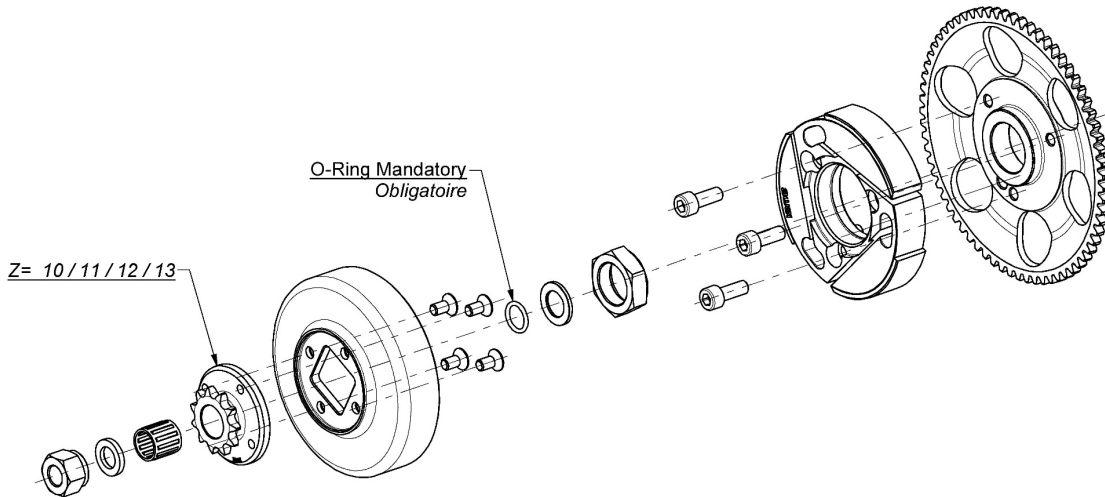


**TILLOTSON HW-50A CARBURETTOR - VENTURI DIMENSIONS**  
**DIMENSIONS DU VENTURI DU CARBURATEUR TILLOTSON HW-50A**

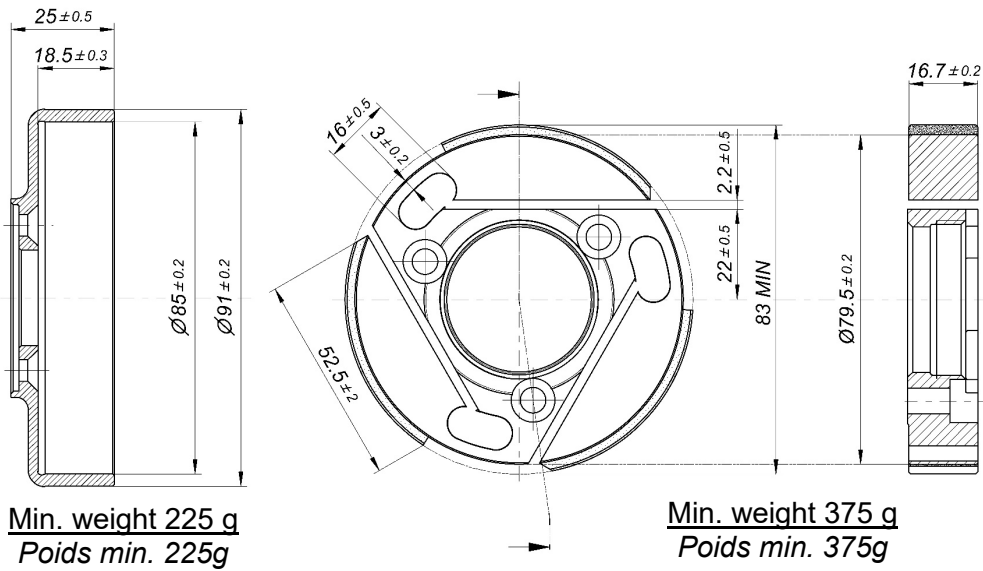


**Tillotson HW-50A**

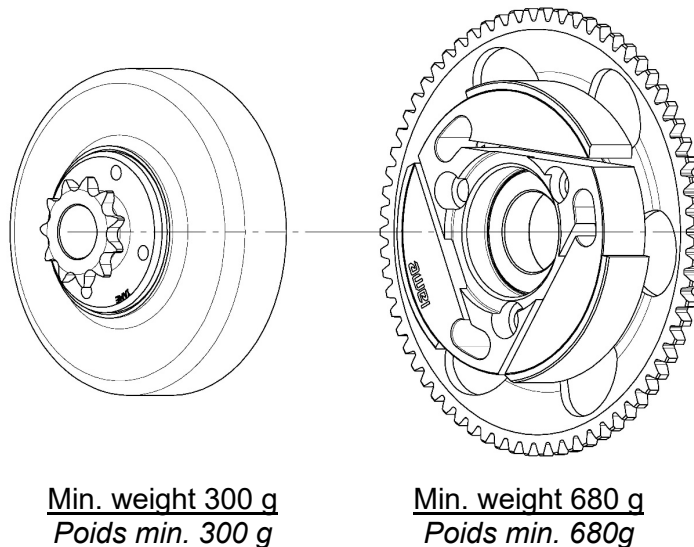
## CLUTCH ASSEMBLY - GROUPE EMBRAYAGE



## COMPONENTS OF THE CLUTCH – COMPOSANTS DE L'EMBRAYAGE

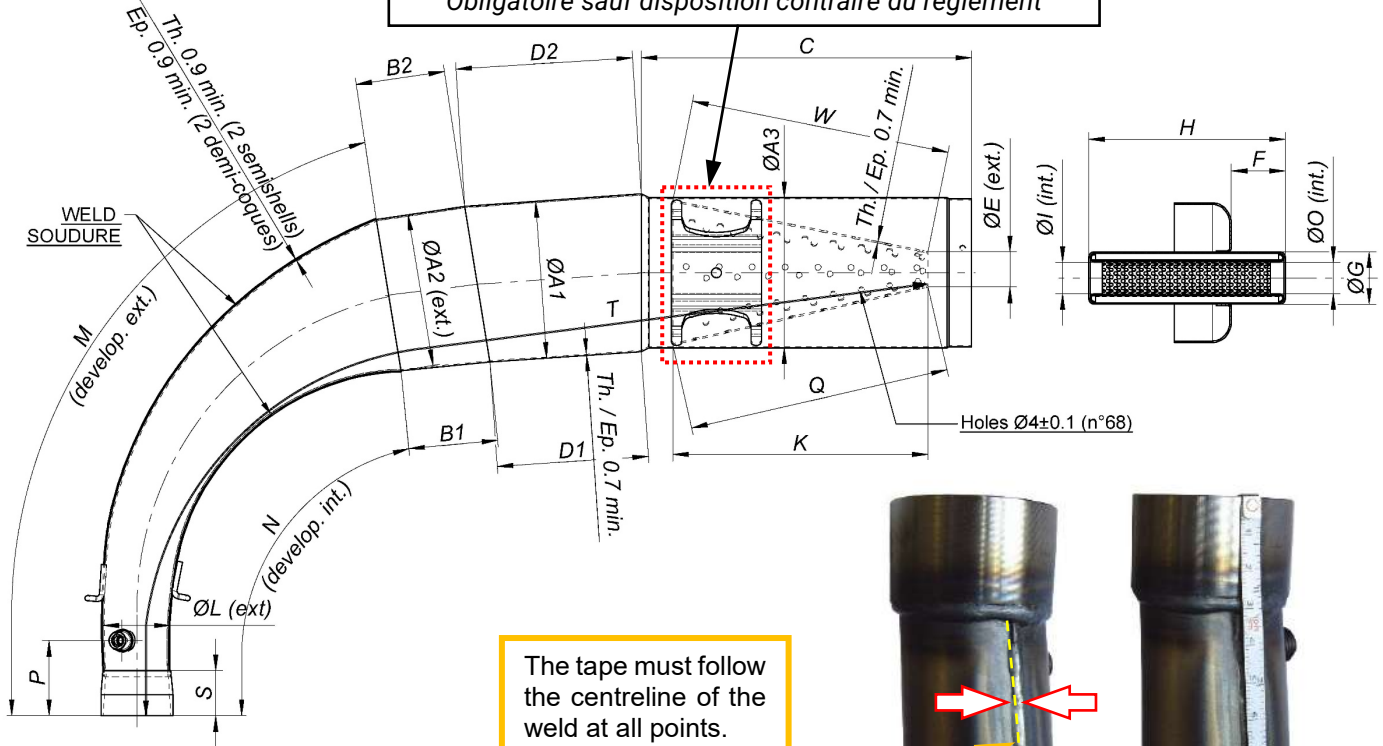


## MINIMUM WEIGHT OF THE CLUTCH – POIDS MIN. DE L'EMBRAYAGE



## EXHAUST DRAWING AND DIMENSIONS DESSIN ET DIMENSIONS DE L'ÉCHAPPEMENT

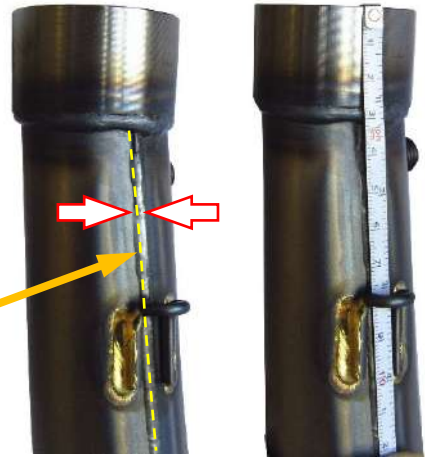
Mandatory unless otherwise prescribed by the regulation  
Obligatoire sauf disposition contraire du règlement



Min. Weight 1.820 g  
Poids min. 1.820 g

The tape must follow the centreline of the weld at all points.

Le ruban doit suivre l'axe de la soudure en tous points.



<b>ØA1:</b> 105 ±1.5 Øext.	<b>B2:</b> 59.5 ±3	<b>ØE:</b> 23.5 ±2 Øext.	<b>ØI:</b> 21 ±1 Øint.	<b>N:</b> 316 ±3	<b>T:</b> 675 ±3
<b>ØA2:</b> 102 ±1.5 Øext.	<b>C:</b> 220 ±3	<b>F:</b> 36 ±2	<b>K:</b> 170 ±3	<b>ØO:</b> 21 ±1 Øint.	<b>W:</b> 170 ±3
<b>ØA3:</b> 100 ±1.5 Øext.	<b>D1:</b> 101 ±3	<b>ØG:</b> 35 ±1 Øext.	<b>ØL:</b> 44 ±1.5 Øext.	<b>P:</b> 50 ±10	<b>Q:</b> 182 ±3
<b>B1:</b> 59.5 ±3	<b>D2:</b> 118 ±3	<b>H:</b> 131 ±3	<b>M:</b> 411 ±3	<b>S:</b> 30 ±1.5	

### ATTENTION:

The dimensions “**M**”, “**N**” and “**T**” must be taken by steel tape measure 6mm wide.  
The dimensions “**M**” and “**N**” must be taken on the weld centerline.

*Les dimensions « **M** », « **N** » et « **T** » doivent être à prises à l'aide d'un ruban à mesurer en acier 6 mm de large.*

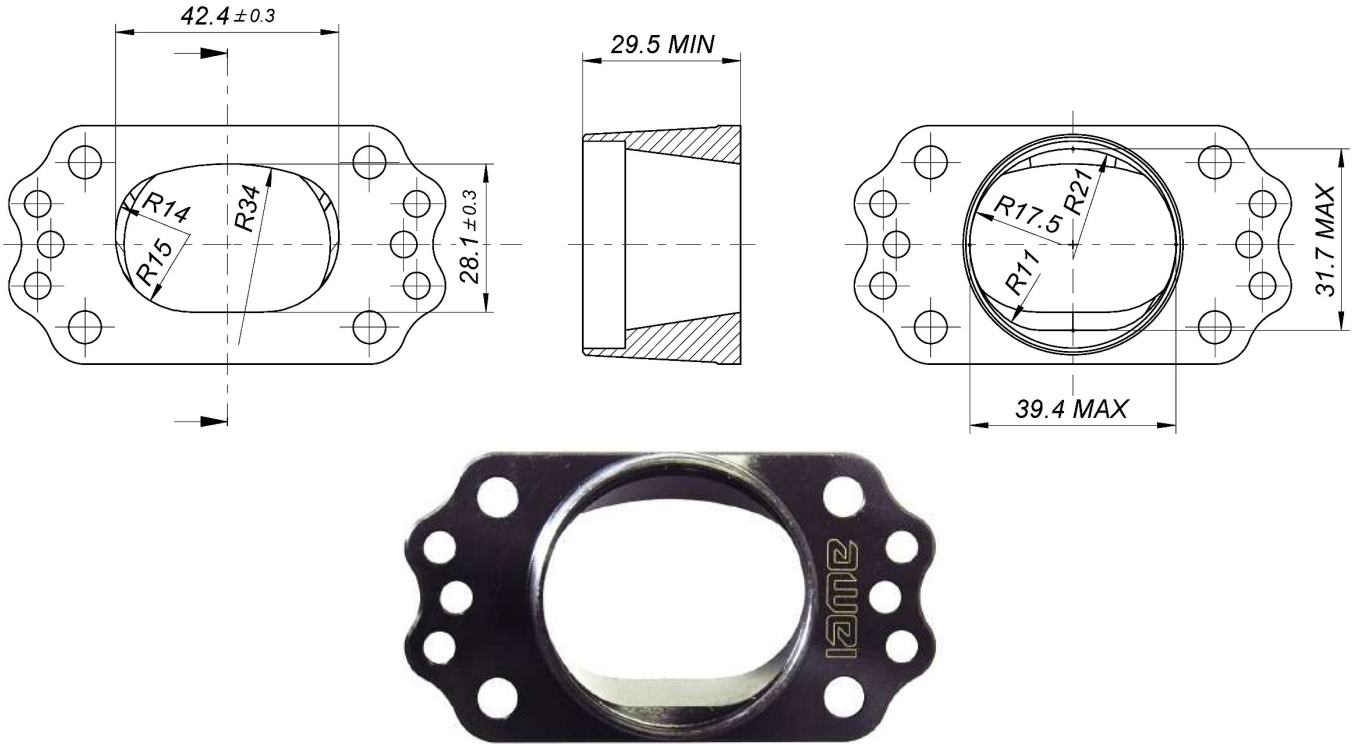
*Les dimensions « **M** », « **N** » doivent être prises sur l'axe de la soudure.*

The dimensions “**Q**” and “**W**” must be taken by steel tape measure 12mm wide.

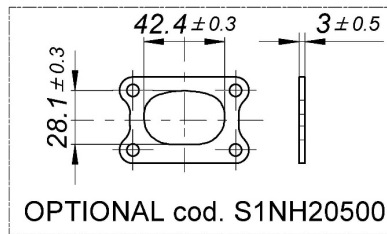
*Les dimensions « **Q** » et « **W** » doivent être prises à l'aide d'un ruban à mesurer en acier 12 mm de large.*



EXHAUST HEADER (Senior) - DIMENSIONS AND MARKING  
 COLLECTEUR D'ÉCHAPPEMENT (Senior) – DIMENSIONS ET MARQUAGE



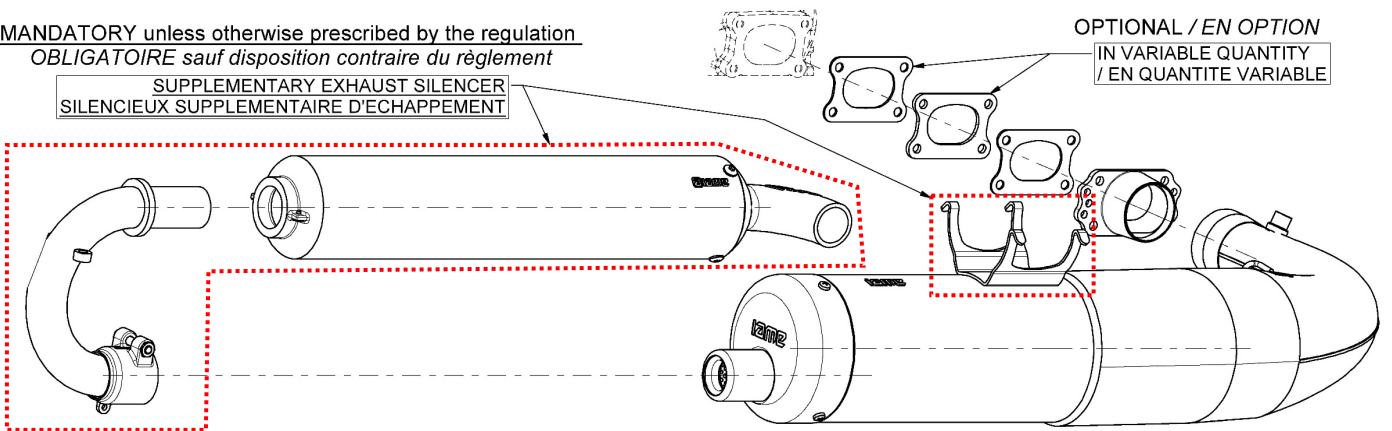
EXHAUST INSTALLATION  
 INSTALLATION DE L'ÉCHAPPEMENT



MANDATORY unless otherwise prescribed by the regulation  
 OBLIGATOIRE sauf disposition contraire du règlement

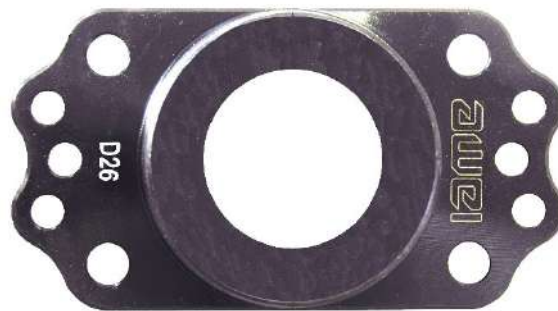
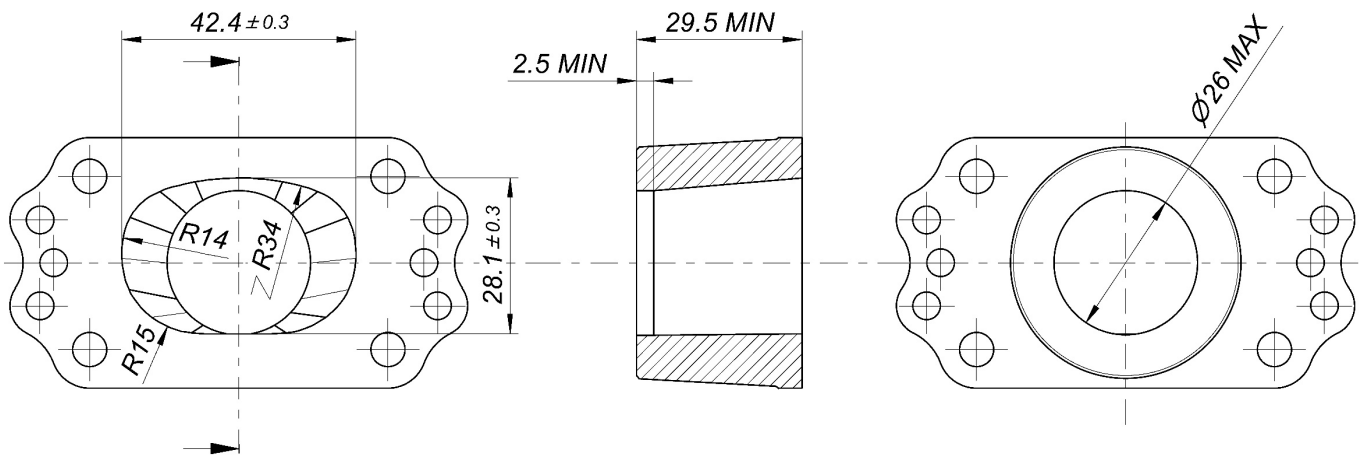
SUPPLEMENTARY EXHAUST SILENCER  
 SILENCIEUX SUPPLÉMENTAIRE D'ÉCHAPPEMENT

OPTIONAL / EN OPTION  
 IN VARIABLE QUANTITY  
 / EN QUANTITÉ VARIABLE

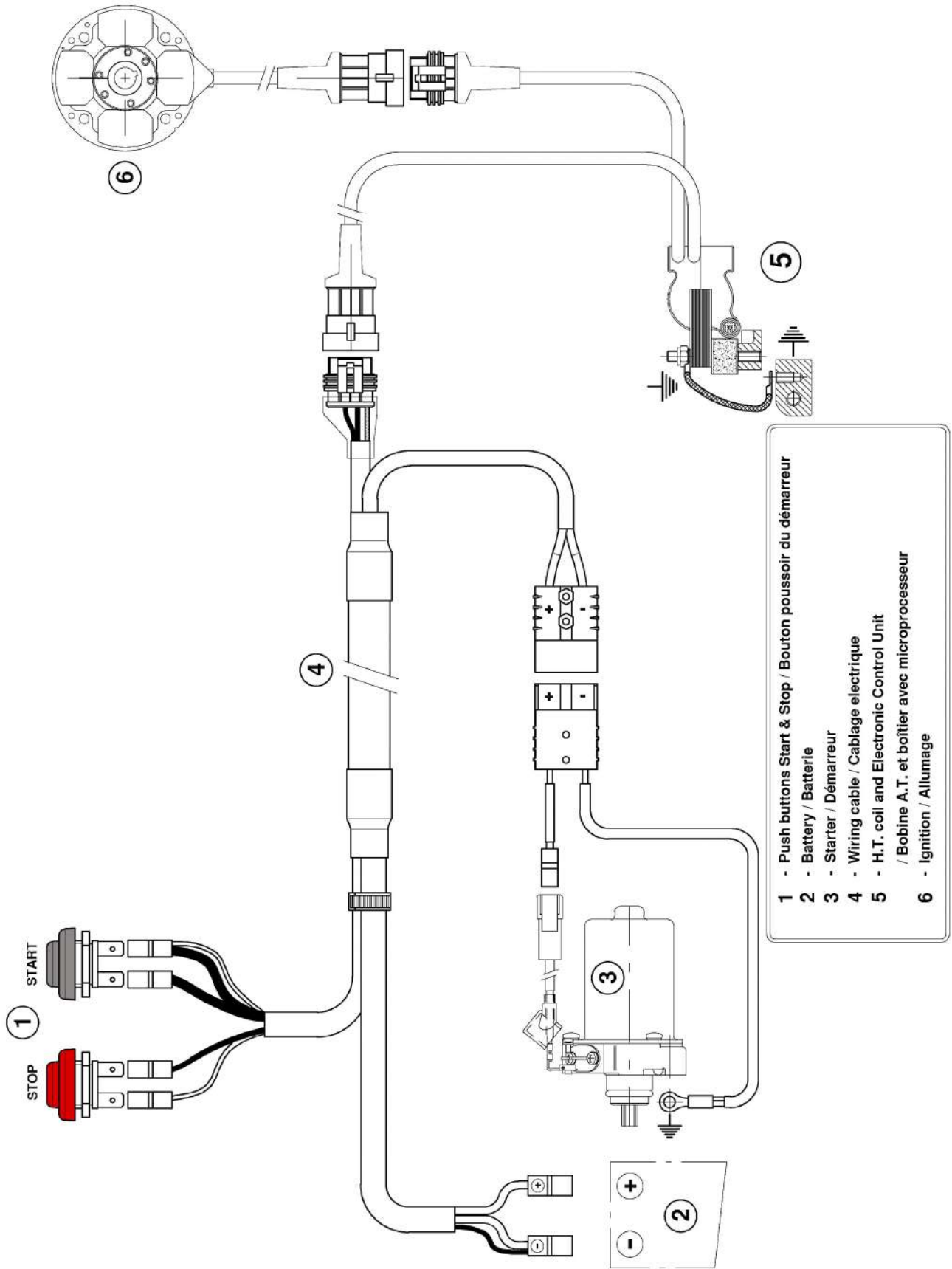


EXHAUST HEADER (Junior) - DIMENSIONS AND MARKING  
COLLECTEUR D'ÉCHAPPEMENT (Junior) – DIMENSIONS ET MARQUAGE

Restrictor / Recstricteur Ø26 mm

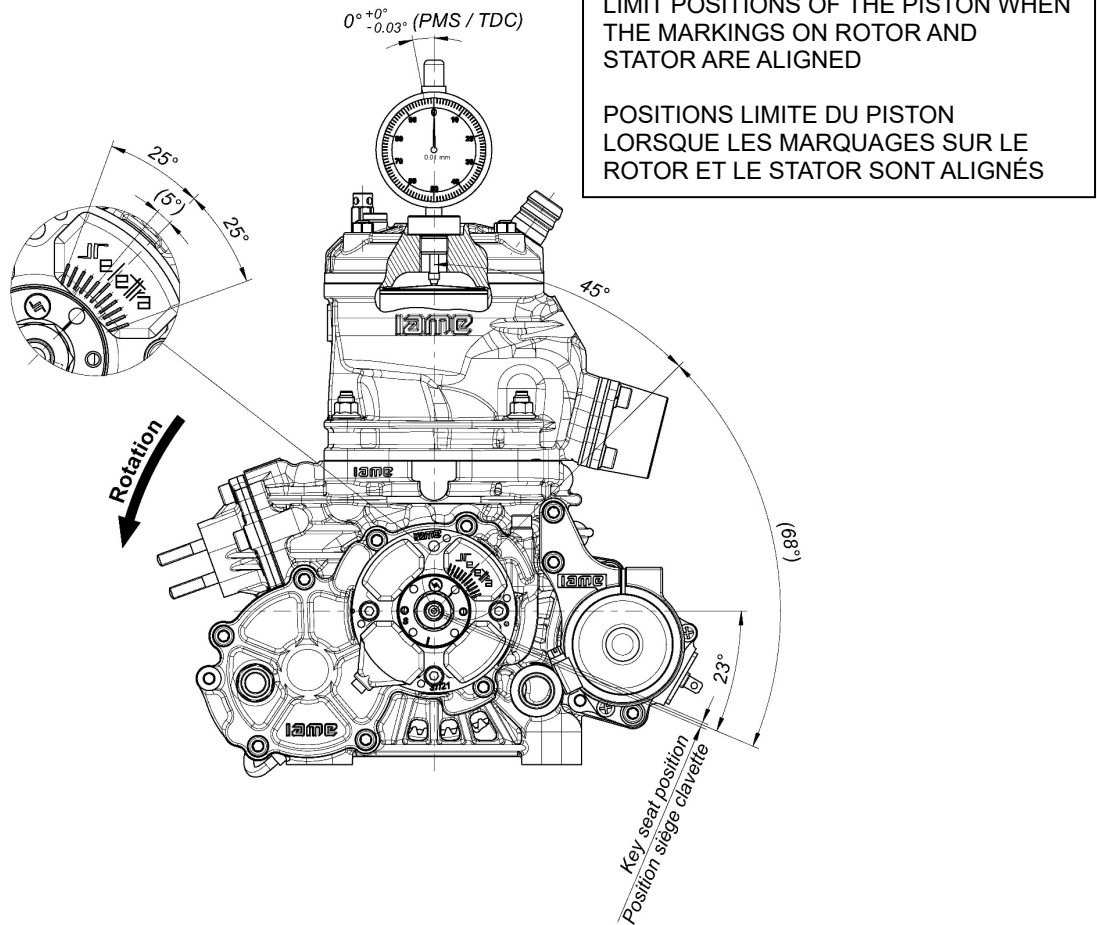


WIRING DIAGRAM (SELETTRA DIGITAL "S" IGNITION)  
 SCHEMA DU CIRCUIT ELECTRIQUE (ALLUMAGE SELETTRA DIGITAL "S")

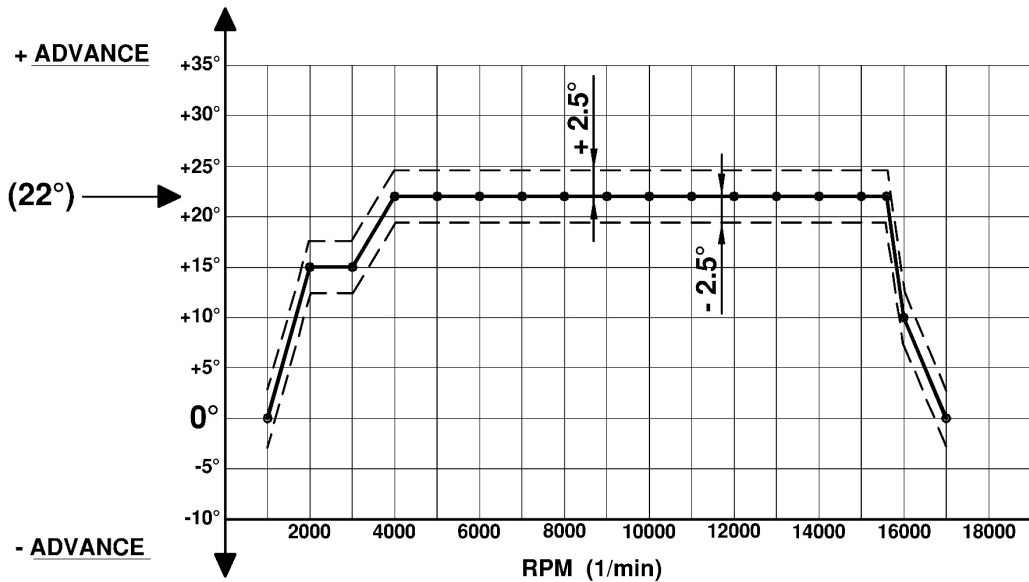


- 1 - Push buttons Start & Stop / Bouton poussoir du démarreur
- 2 - Battery / Batterie
- 3 - Starter / Démarreur
- 4 - Wiring cable / Cablage électrique
- 5 - H.T. coil and Electronic Control Unit / Bobine A.T. et boîtier avec microprocesseur
- 6 - Ignition / Allumage

## SCHEME FOR ADVANCE CHECKING SCHEMA POUR LE CONTROLE DE L'AVANCE



### ADVANCE CURVE GRAPHS / DIAGRAMME DE L'AVANCE



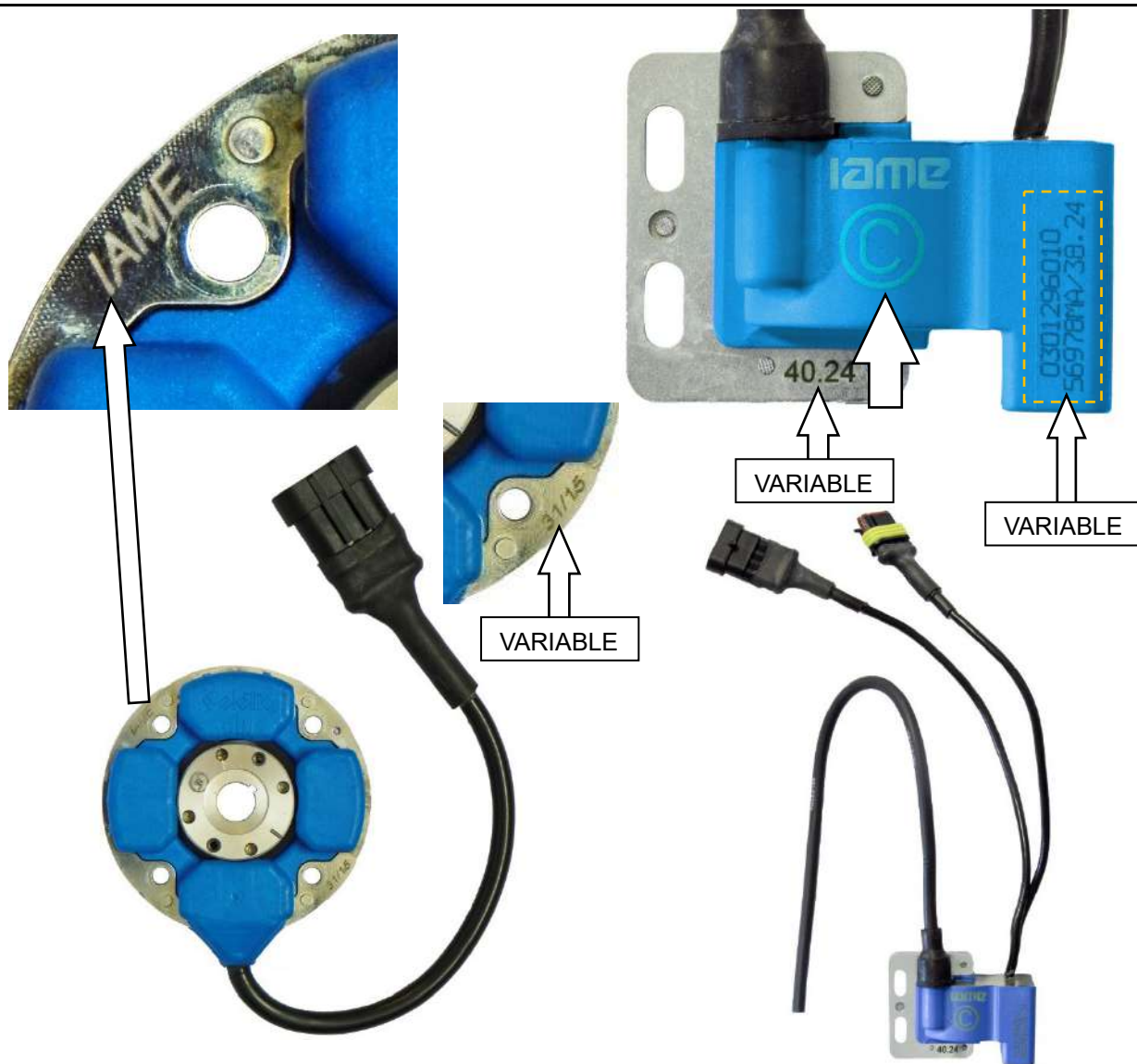
#### "C" MAPPING / MAPPAGE

Tr/ min	1000	2000	3000	4000	5000	6000	7000	8000	9000	10000	11000	12000	13000	14000	15500	16000	17000
°adv	0°	15°	15°	22°	22°	22°	22°	22°	22°	22°	22°	22°	22°	22°	22°	10°	0°

PHOTO OF THE WIRING LOOM – PHOTO DU CABLAGE ELECTRIQUE

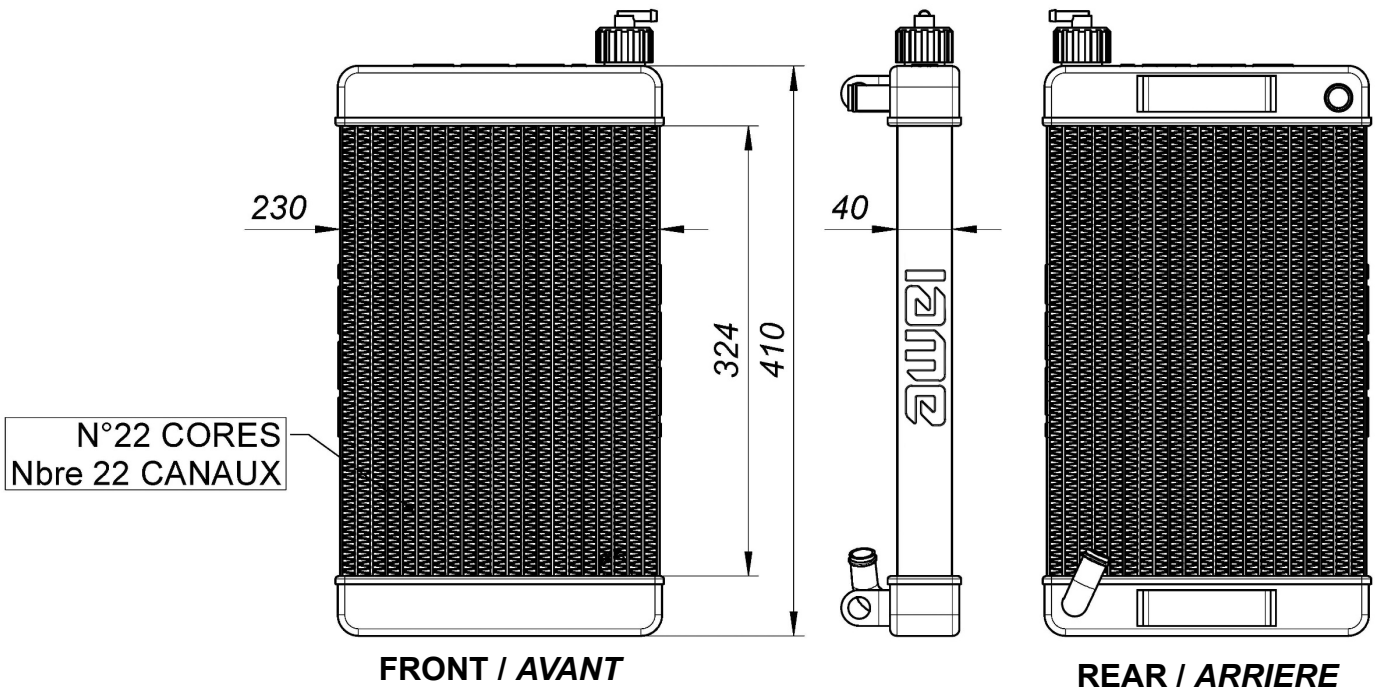


PHOTO OF SELETTA DIGITAL "S" IGNITION WITH "IAME" MARKING  
PHOTO DE L'ALLUMAGE SELETTA DIGITAL "S" AVEC MARQUAGE "IAME"

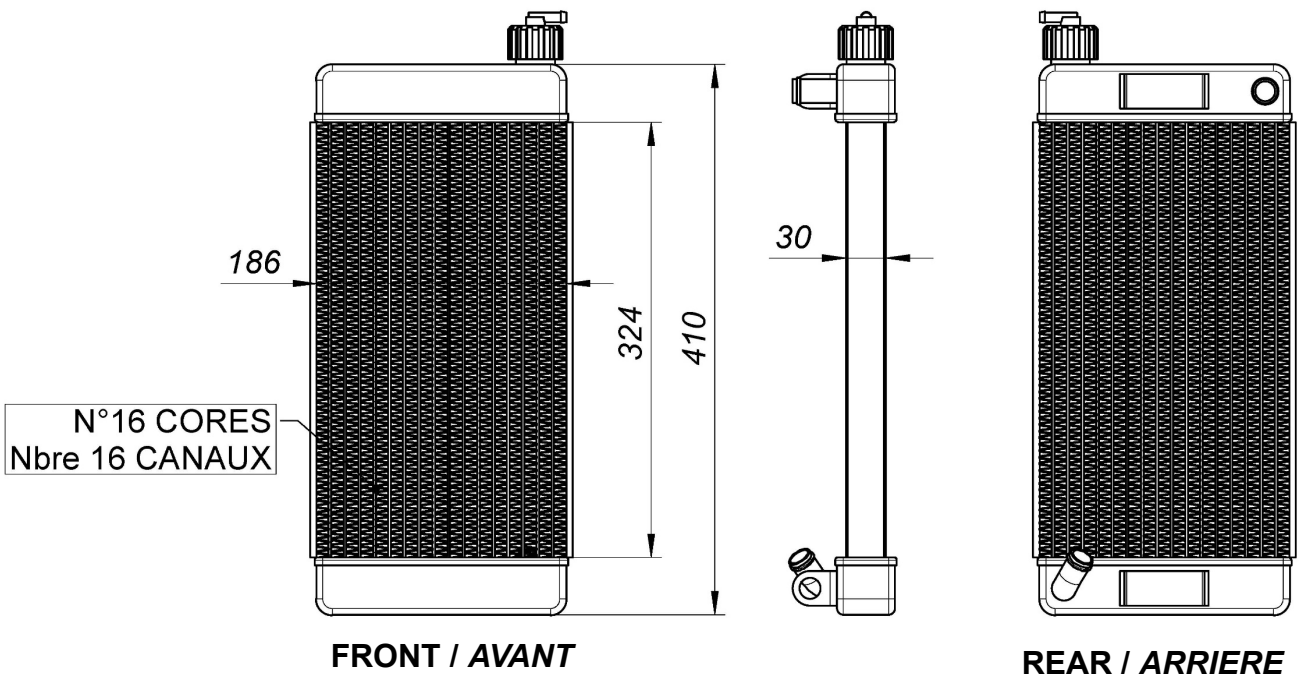




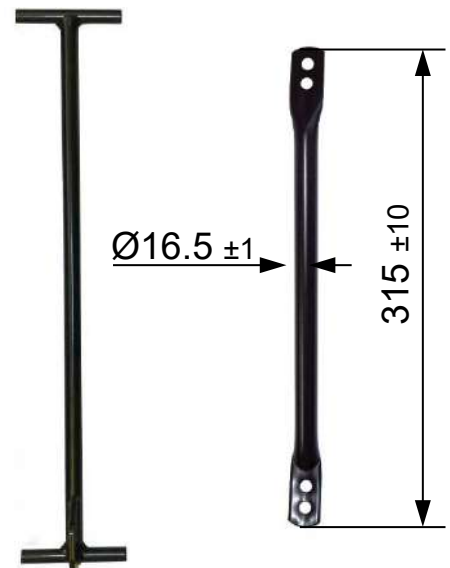
RADIATOR AND SUPPORTS – TYPE 1  
 RADIATEUR ET SES SUPPORTS – TYPE 1



ALTERNATIVE RADIATOR AND SUPPORTS – TYPE 2  
 RADIATEUR ALTERNATIF ET SES SUPPORTS – TYPE 2

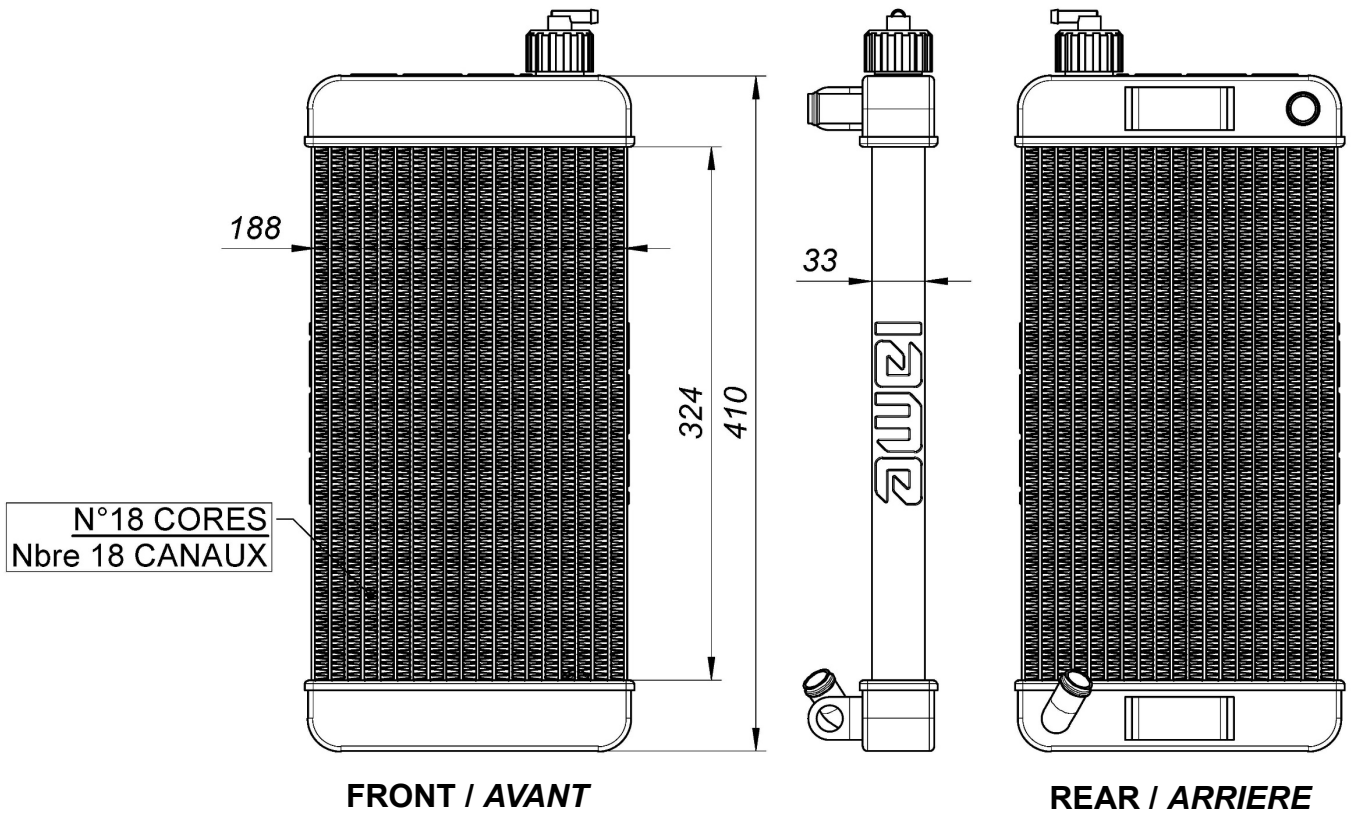


PAINTED AND NOT PAINTED  
 PEINT ET PAS PEINT

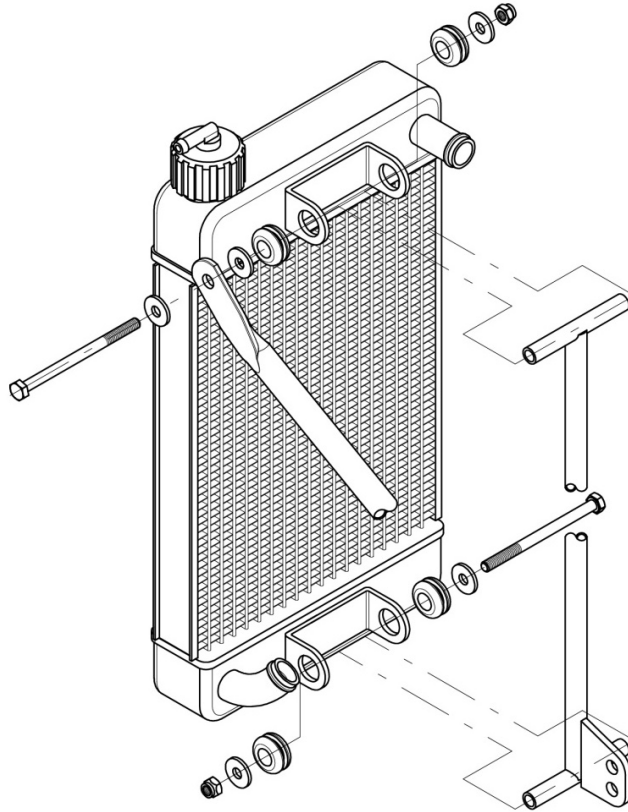




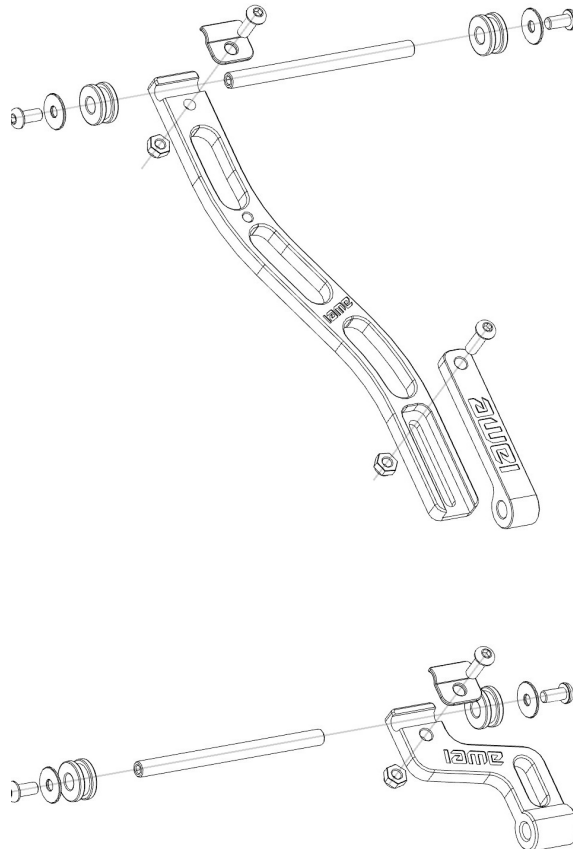
ALTERNATIVE RADIATOR AND SUPPORTS – TYPE 3  
 RADIATEUR ALTERNATIF ET SES SUPPORTS – TYPE 3



RADIATOR ASSY WITH SUPPORTS  
GROUPE RADIATEUR AVEC SES SUPPORTS



ALTERNATIVE SUPPORT  
SUPPORTS ALTERNATIF



THERMOSTAT  
THERMOSTAT



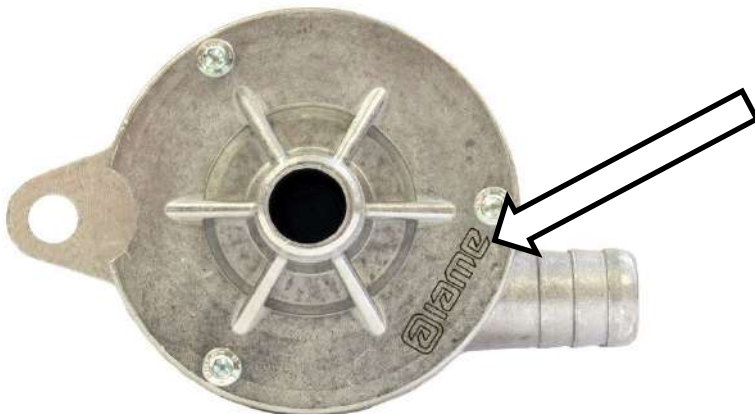
ALTERNATIVE  
ALTERNATIF



WATER PUMP & PULLEY  
GROUPE POMPE À EAU ET POULIE



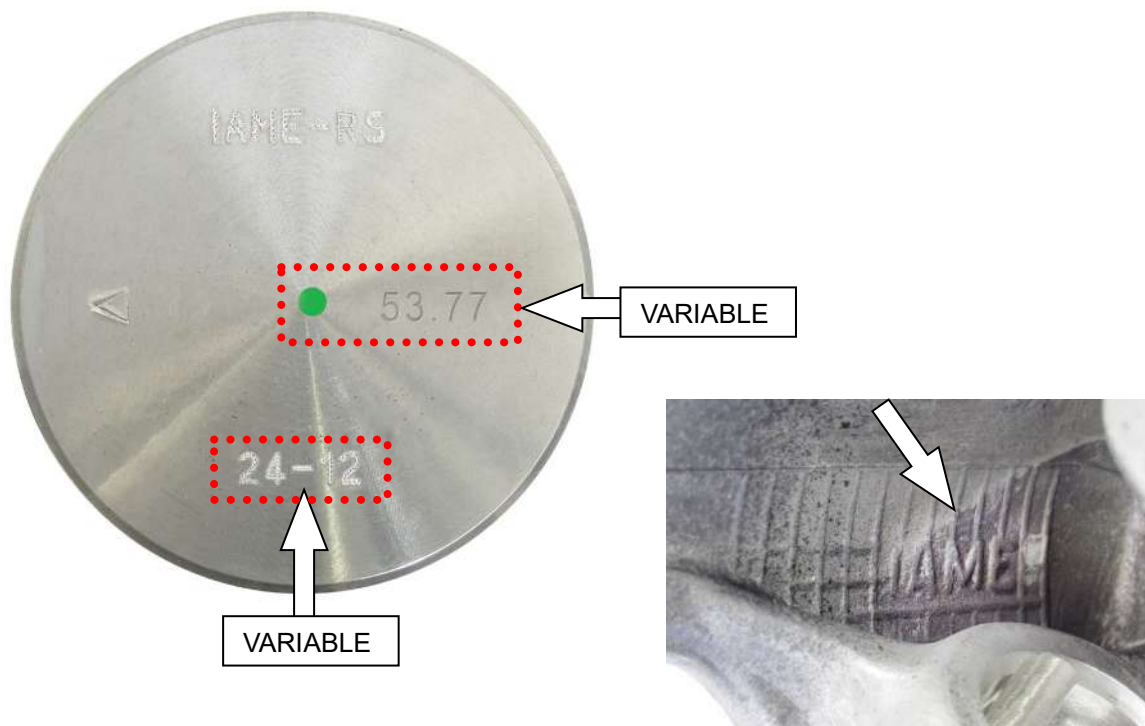
RACE BOTTOM - FOND GORGE  
 $\varnothing 20 \pm 1$



PISTON IDENTIFICATION MARKING  
MARQUAGE D'IDENTIFICATION DU PISTON

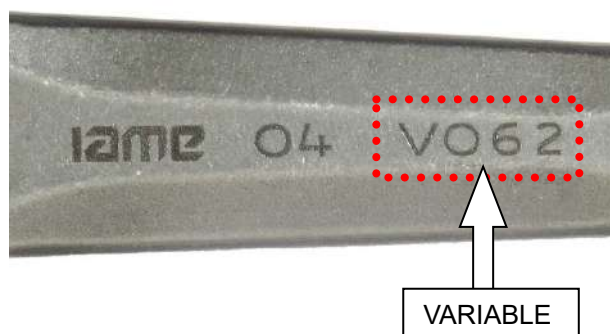


PISTON IDENTIFICATION ALTERNATIVE MARKING  
MARQUAGE ALTERNATIF D'IDENTIFICATION DU PISTON

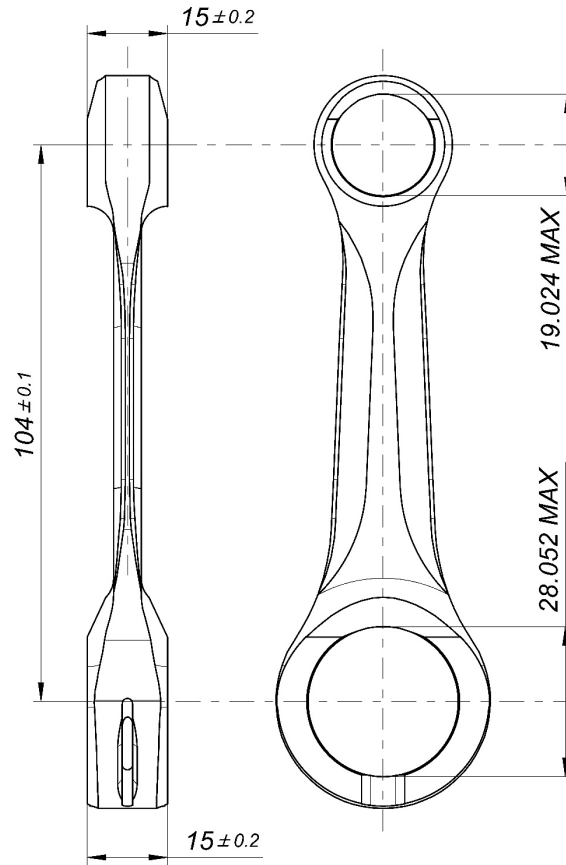




CONROD IDENTIFICATION MARKING  
MARQUAGE D'IDENTIFICATION DE LA BIELLE



ALTERNATIVE CONROD  
BIELLE ALTERNATIVE



Min. weight 121 g  
Poids min. 121 g

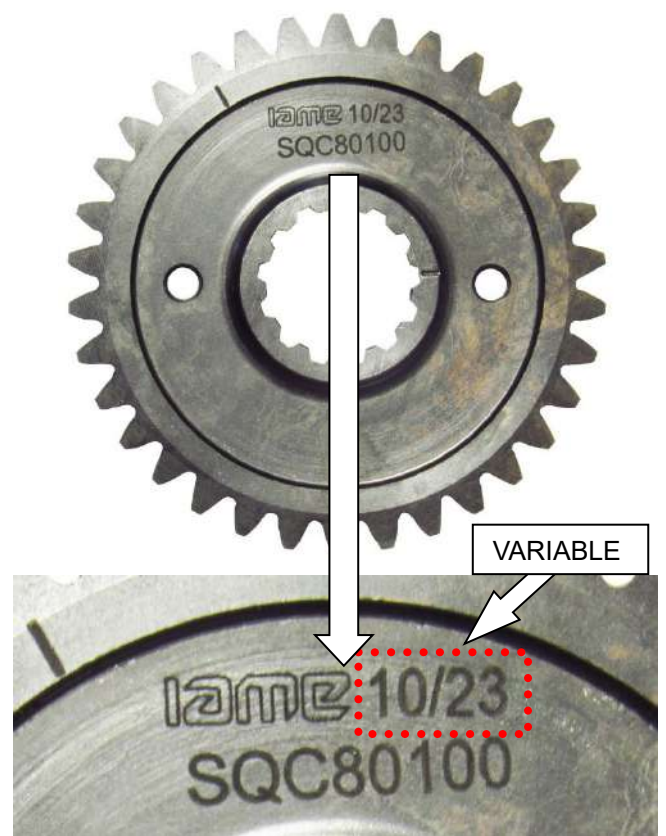
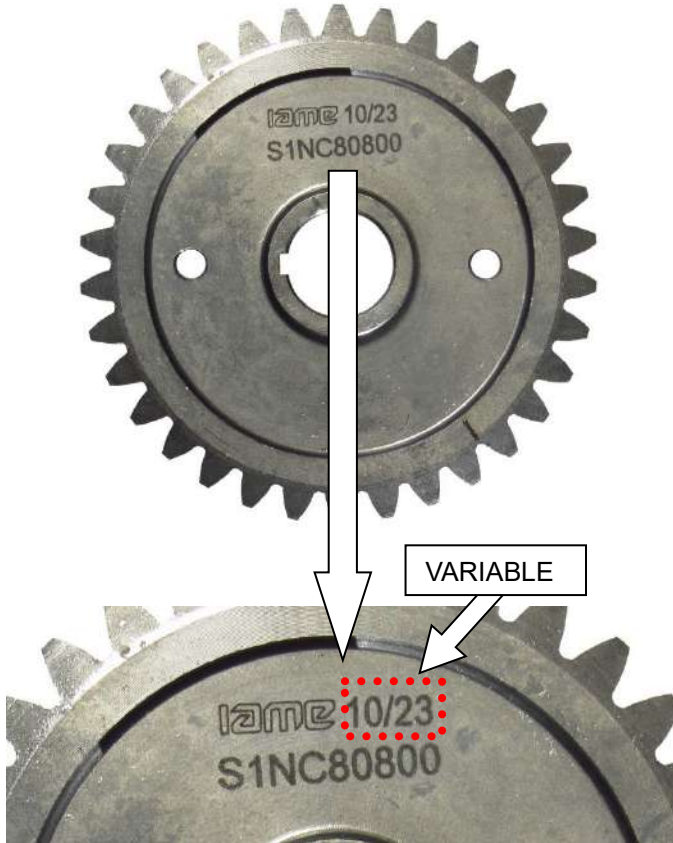
PHOTO OF THE CONROD BOTH SIDES – ALTERNATIVE  
PHOTO DES DEUX COTES DE LA BIELLE – ALTERNATIVE





BALANCER SHAFT GEAR IDENTIFICATION MARKING  
MARQUAGE D'IDENTIFICATION  
ENGRENAGE D'ARBRE D'EQUILIBRAGE

CRANKSHAFT GEAR IDENTIFICATION MARKING  
MARQUAGE D'IDENTIFICATION  
ENGRENAGE VILEBREQUIN



BALANCER SHAFT IDENTIFICATION MARKING  
MARQUAGE D'IDENTIFICATION ARBRE D'EQUILIBRAGE



CRANKSHAFT IDENTIFICATION MARKING  
 MARQUAGE D'IDENTIFICATION DU VILEBREQUIN



SPROCKET IDENTIFICATION MARKING  
 MARQUAGE D'IDENTIFICATION DU PIGNON



CLUTCH DRUM IDENTIFICATION MARKING  
 MARQUAGE D'IDENTIFICATION DE LA CALOTTE





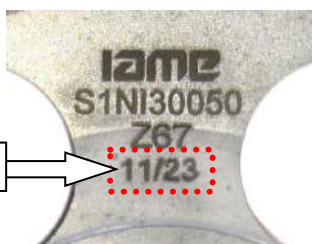
CLUTCH HUB IDENTIFICATION MARKING  
 MARQUAGE D'IDENTIFICATION DU MOYEU D'EMBAYAGE



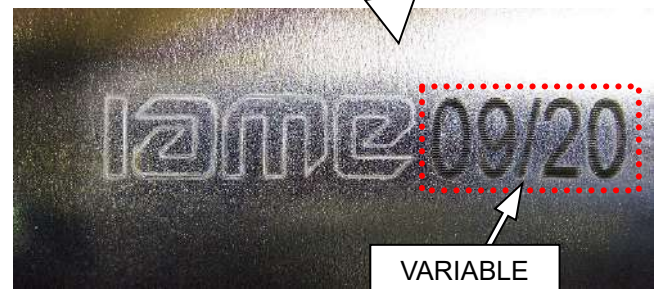
ALTERNATIVE  
 FRICTION MATERIAL  
 -----  
 MATÉRIAU DE  
 FRICTION  
 ALTERNATIVE



STARTER RING IDENTIFICATION MARKING  
 MARQUAGE D'IDENTIFICATION DE LA  
 COURONNE DE DEMARRAGE



STARTER IDENTIFICATION MARKING  
 MARQUAGE D'IDENTIFICATION DU  
 DEMARREUR



REED GROUP & PETALS IDENTIFICATION MARKING  
 MARQUAGE D'IDENTIFICATION DE LA BOÎTE À CLAPETS ET DES CLAPETS



**MATERIAL: CARBON FIBER**  
 Thickness / Epaisseur  
 minimum: 0.22 mm

INLET CONVEYOR  
 PHOTO IDENTIFICATION  
 MARQUAGE D'IDENTIFICATION DU  
 COLLECTEUR D'ADMISSION

CLUTCH COVER IDENTIFICATION MARKING  
 MARQUAGE DU COUVERCLE  
 D'EMBRAYAGE





PHOTO OF THE INSIDE OF THE RIGHT CRANKCASE  
*PHOTO INTÉRIEUR DU CARTER DROIT*



PHOTO OF THE INSIDE OF THE LEFT CRANKCASE  
*PHOTO INTÉRIEUR DU CARTER GAUCHE*

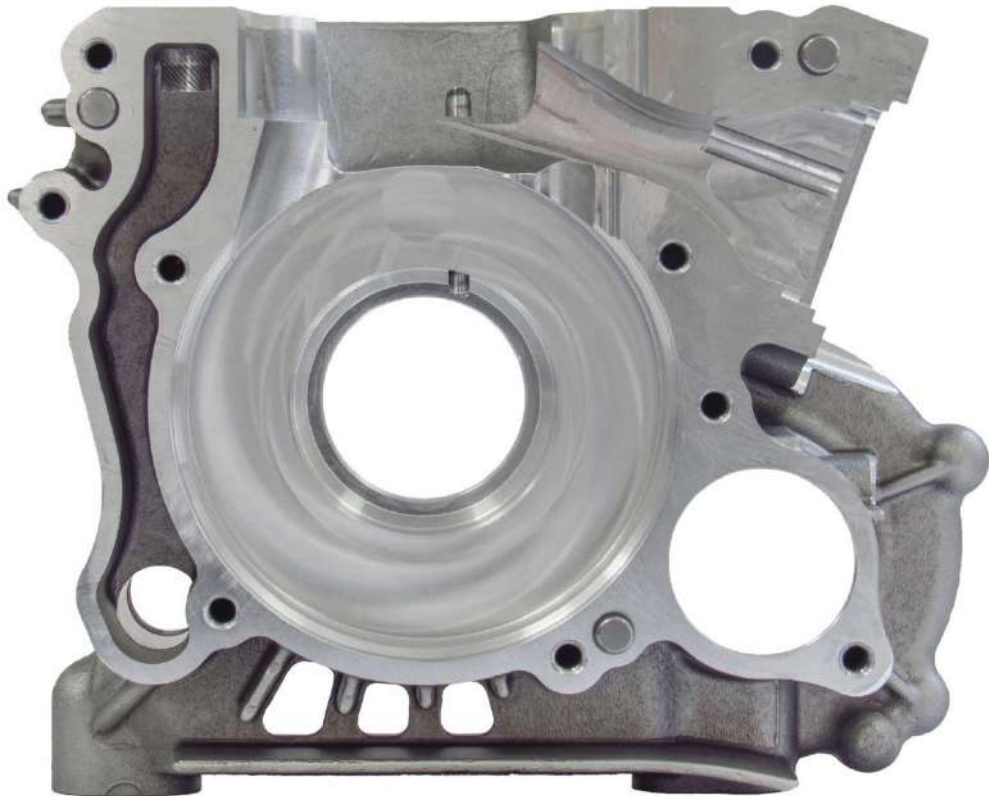
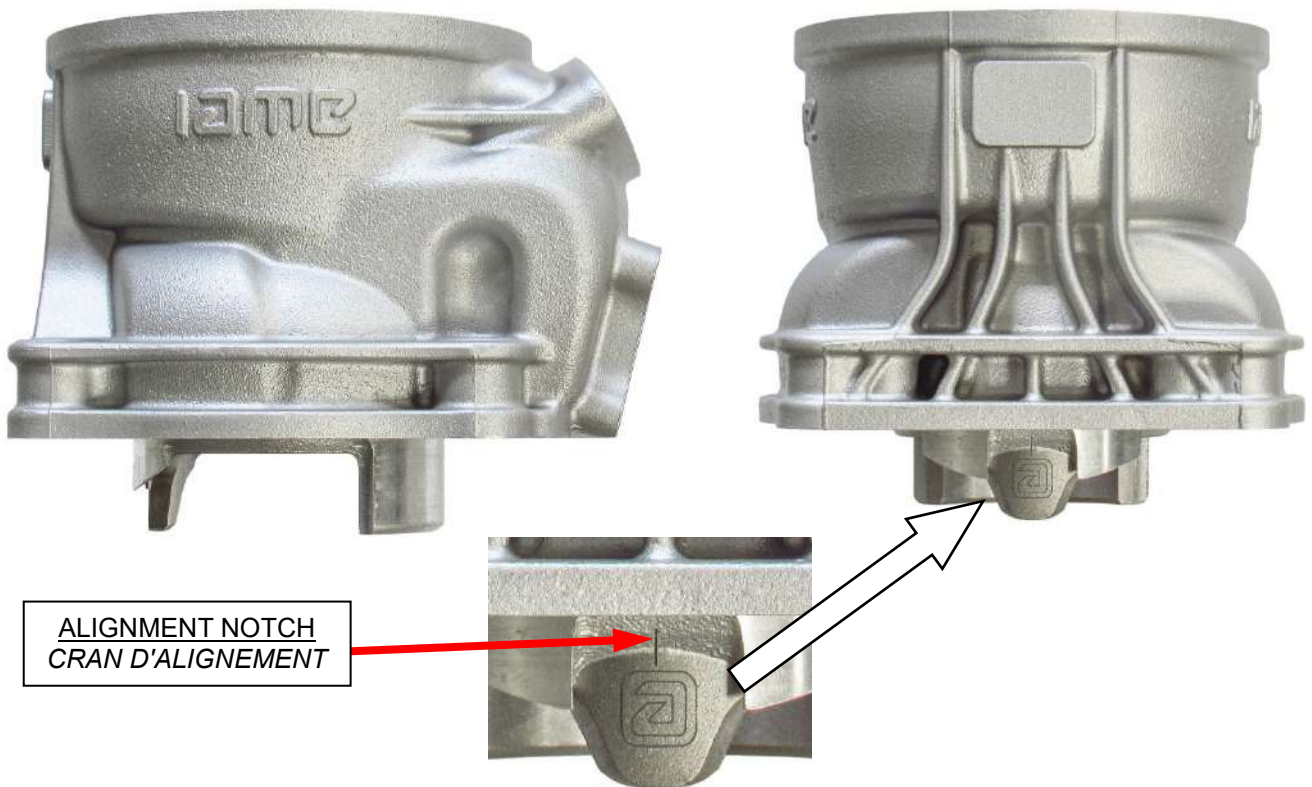


PHOTO IDENTIFICATION CYLINDER HEAD  
*PHOTO D'IDENTIFICATION DE LA CULASSE DU CILINDRE*

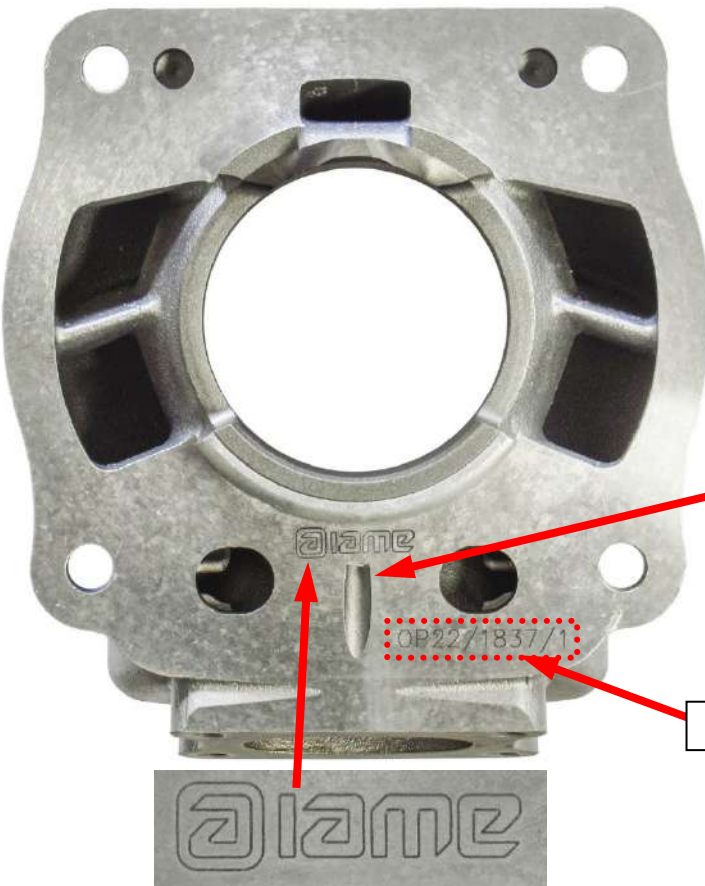
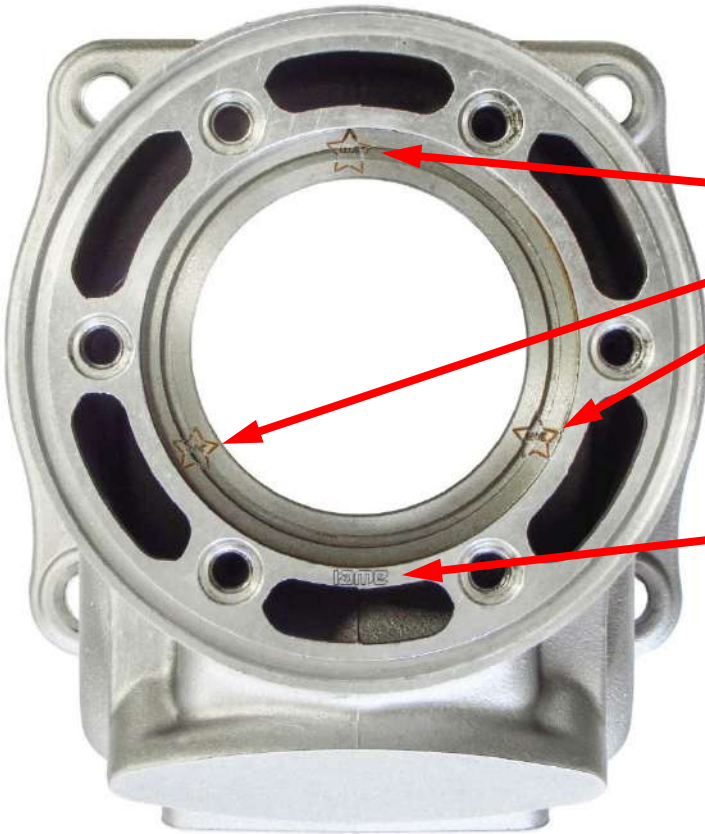


CYLINDER IDENTIFICATION MARKING  
*MARQUAGE D'IDENTIFICATION DU CYLINDRE*





CYLINDER IDENTIFICATION MARKING  
MARQUAGE D'IDENTIFICATION DU CYLINDRE



**MANDATORY LINER LOCKING PIN**  
**GOUPILLE OBLIGATOIRE DE BLOCAGE DE LA**  
**CHEMISE**

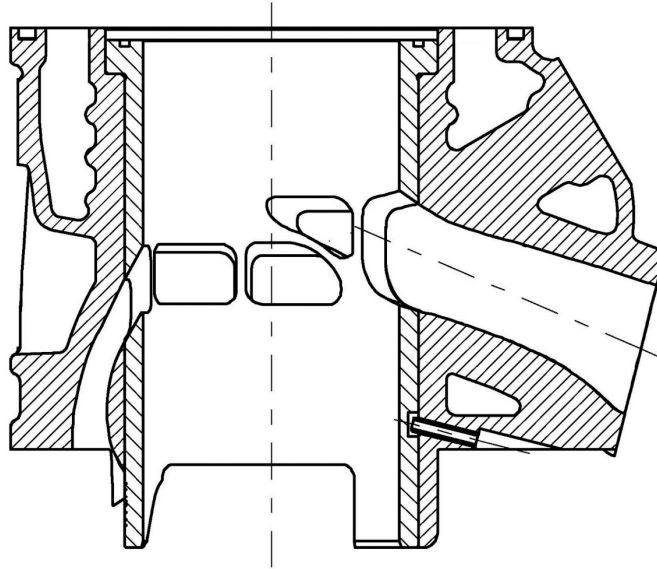
VARIABLE



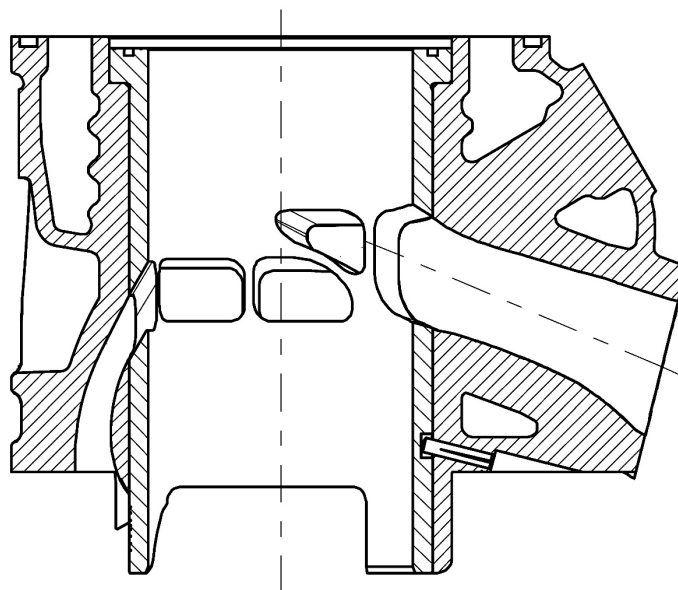
**FROM 2025 ON - A PARTIR DE 2025**

CYLINDER IDENTIFICATION – ALTERNATIVE CYLINDER LINER LOCKING PIN  
*IDENTIFICATION DU CYLINDRE – GOUPILLE DE BLOCAGE DE LA CHEMISE ALTERNATIF*

CURRENT PIN (SPRING PIN)  
*GOUPILLE COURANTE (GOUPILLE À RESORT)*



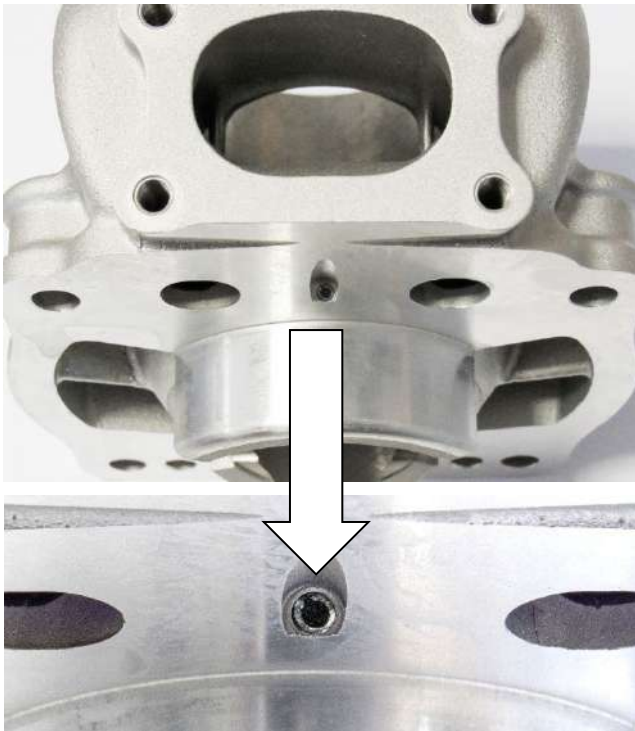
ALTERNATIVE PIN (GROOVED PIN)  
*GOUPILLE ALTERNATIF - (GOUPILLE CANNELÉE)*



**FROM 2025 ON - A PARTIR DE 2025**

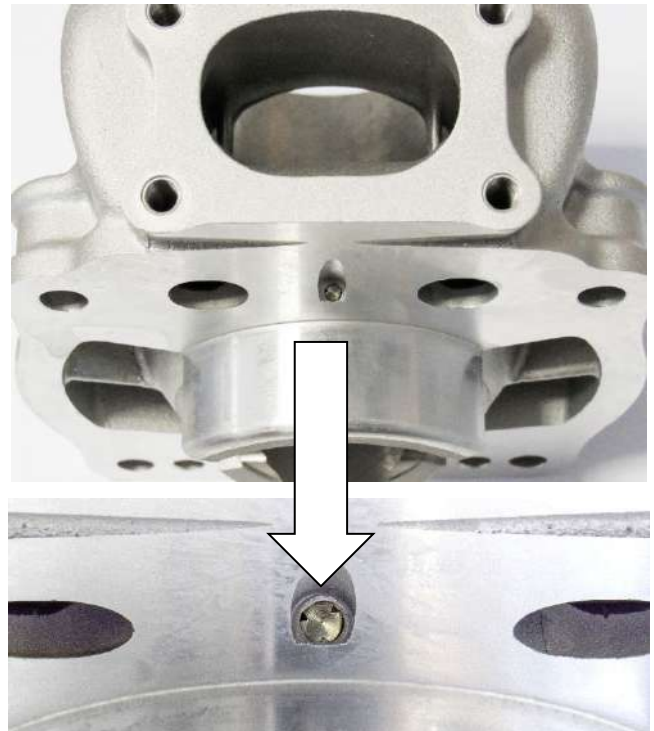
CYLINDER IDENTIFICATION – ALTERNATIVE CYLINDER LINER LOCK PIN  
*IDENTIFICATION DU CYLINDRE – GOUPILLE DE BLOCAGE DE LA ACHEMISE ALTERNATIF*

**CURRENT PIN  
GOUPILLE COURANTE**



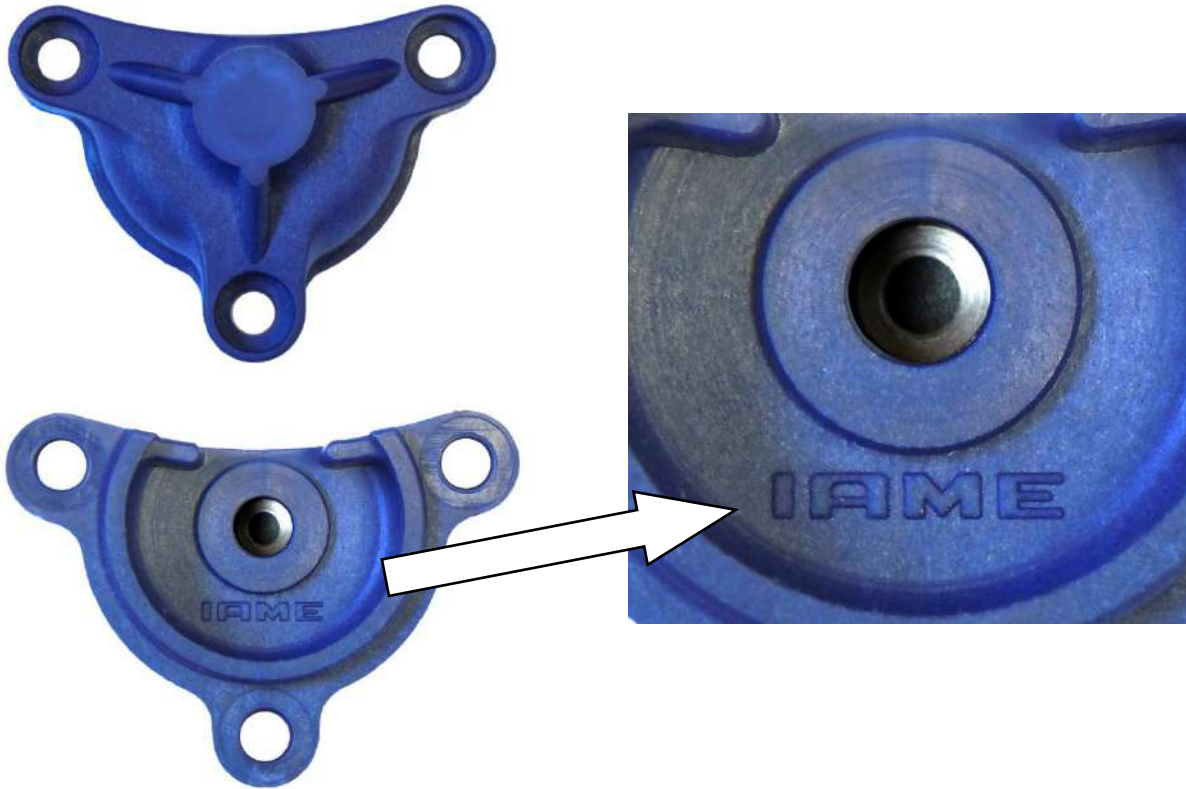
**SPRING PIN  
GOUPILLE À RESORT**

**ALTERNATIVE PIN  
GOUPILLE ALTERNATIF**



**GROOVED PIN  
GOUPILLE CANNELÉE**

BENDIX COVER IDENTIFICATION MARKING  
MARQUAGE D'IDENTIFICATION DU COUVERCLE  
DU BENDIX



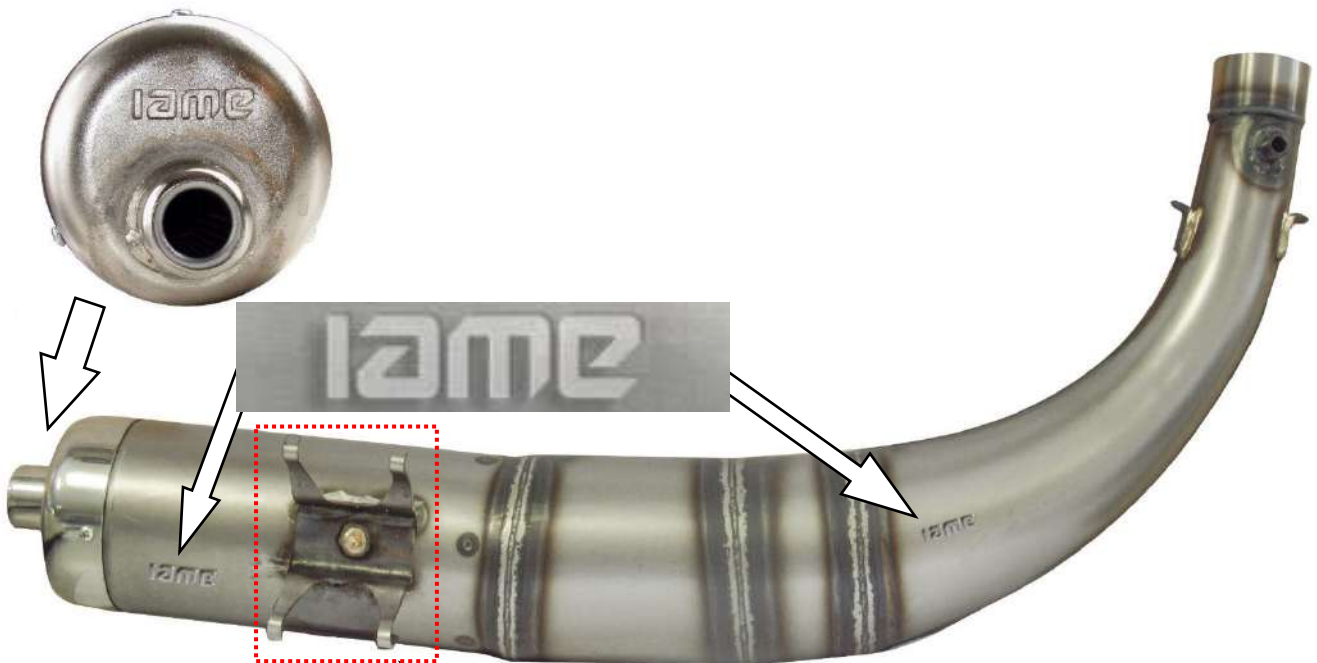
GEARS COVER IDENTIFICATION MARKING  
MARQUAGE D'IDENTIFICATION DU COUVERCLE  
ENGRENAGES



STARTER SUPPORT IDENTIFICATION MARKING  
MARQUAGE D'IDENTIFICATION DU SUPPORT DEMARREUR

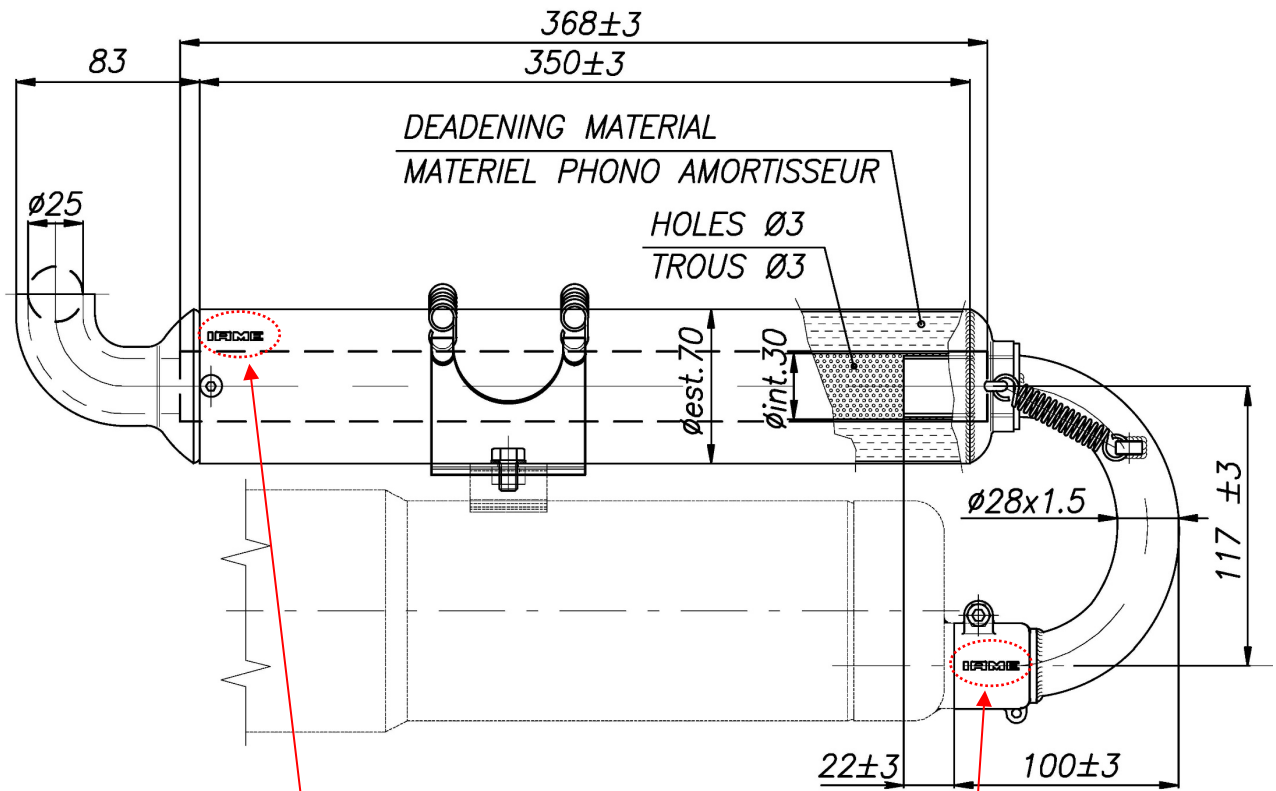


EXHAUST IDENTIFICATION MARKING  
MARQUAGE D'IDENTIFICATION D'ECHAPPEMENT



Mandatory unless otherwise prescribed by the regulation  
Obligatoire sauf disposition contraire du règlement

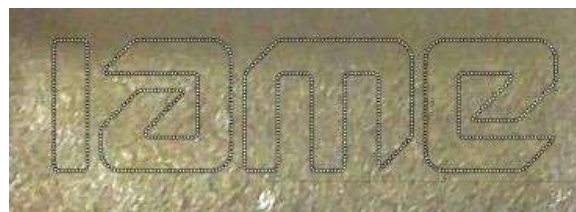
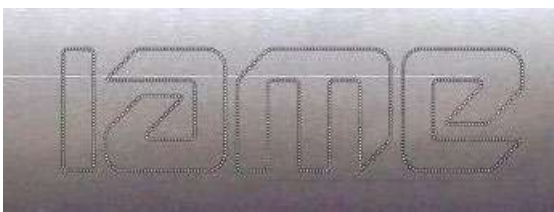
**EXHAUST SILENCER (Mandatory unless otherwise prescribed by the regulation)**  
**SILENCIEUX D'ÉCHAPPEMENT (Obligatoire sauf disposition contraire du règlement)**



OR / OU



OR / OU



**IAME MARKING / MARQUAGE IAME**



**THE OTHERS COMPONENTS OF ENGINE THAT ARE MARKED (LASER OR PUNCHING) UNTIL TODAY WITH LOGO OR WRITTEN "IAME"**

**LES AUTRES COMPOSANTS DU MOTEUR AVEC COMME MARQUAGE (LASER OU POINÇONNEUSE) L'ANCIEN LOGO OU ÉCRIT «IAME»**

I A M E

**or**

**IAME**

**NOW COULD BE MARKED WITH NEW LOGO "IAME"**

**POURRAIENT MAINTENANT ETRE MARQUES AVEC LE NOUVEAU LOGO "IAME"**

i a m e

**or**

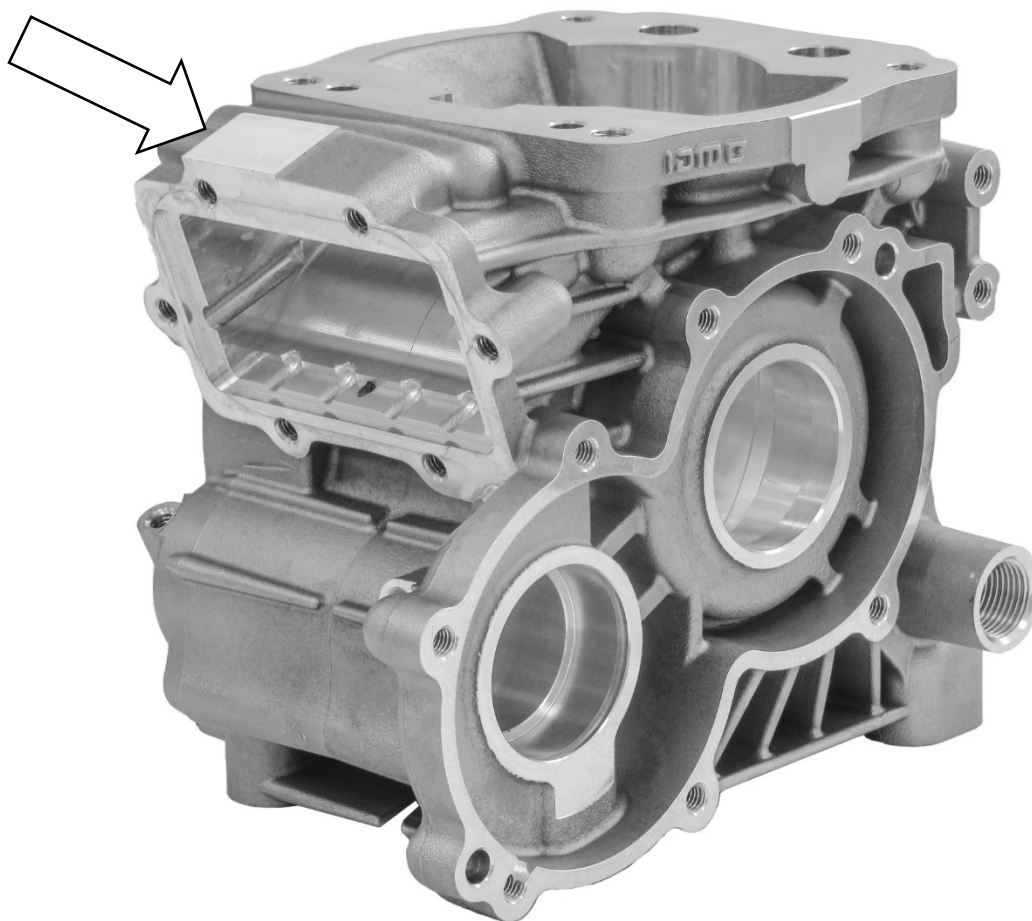
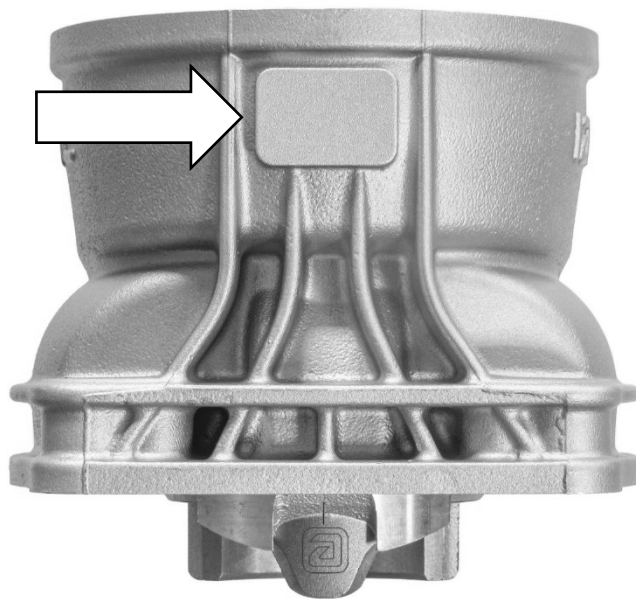
ⓐ i a m e

**or**

ⓐ



STICKER APPLICATION AREA - *ESPACE POUR L'APPLICATION DES ADHÉSIFS*





# CARBURETTOR / CARBURATEUR TILLOTSON HW-50A



PHOTO OF ADJUSTING SIDE  
PHOTO CÔTÉ RÉGLAGE



PHOTO OF INLET SIDE  
PHOTO CÔTÉ D'ADMISSION

Manufacturer - *Constructeur*

**TILLOTSON LTD.**

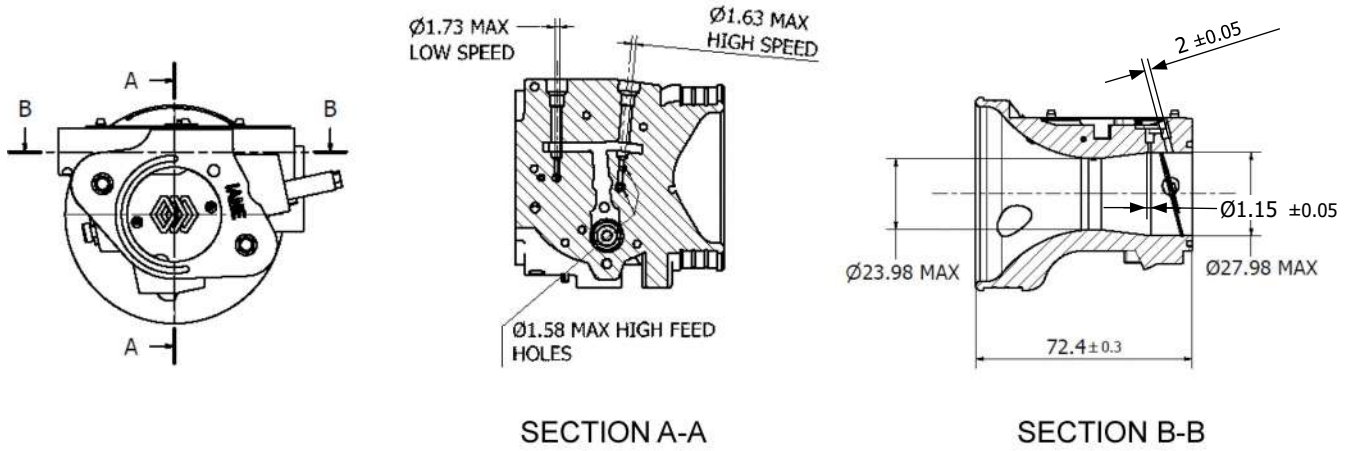
Make - *Marque*

**TILLOTSON**

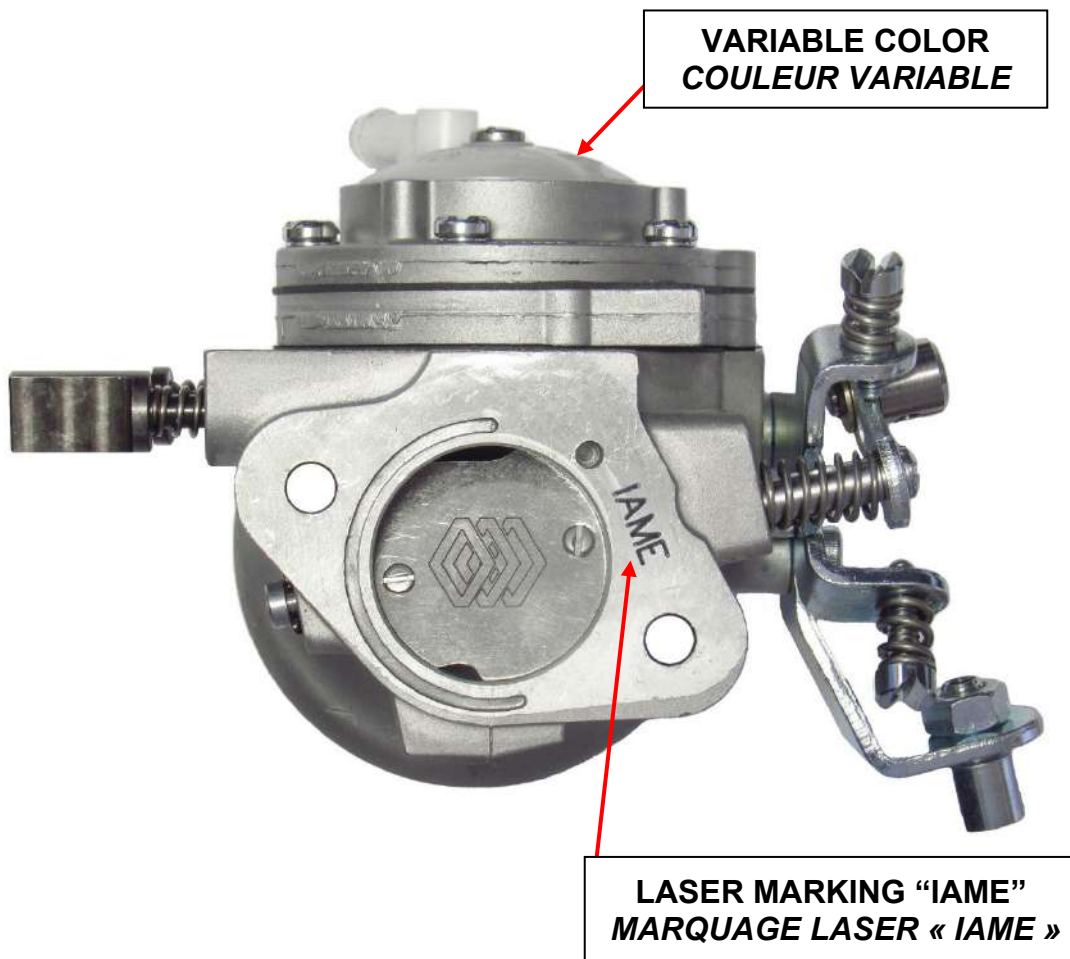
Model - *Modèle*

**HW-50A**

SECTION VIEW – VUE DE SECTION AVEC DIMENSIONS



MARKING « IAME » – MARQUAGE « IAME »



# CARBURETTOR DESCRIPTION AND SKETCH OF PARTS CARBURATEUR - DESCRIPTION ET DESSIN DES PIÈCES

HW-50A EXPLODED VIEW

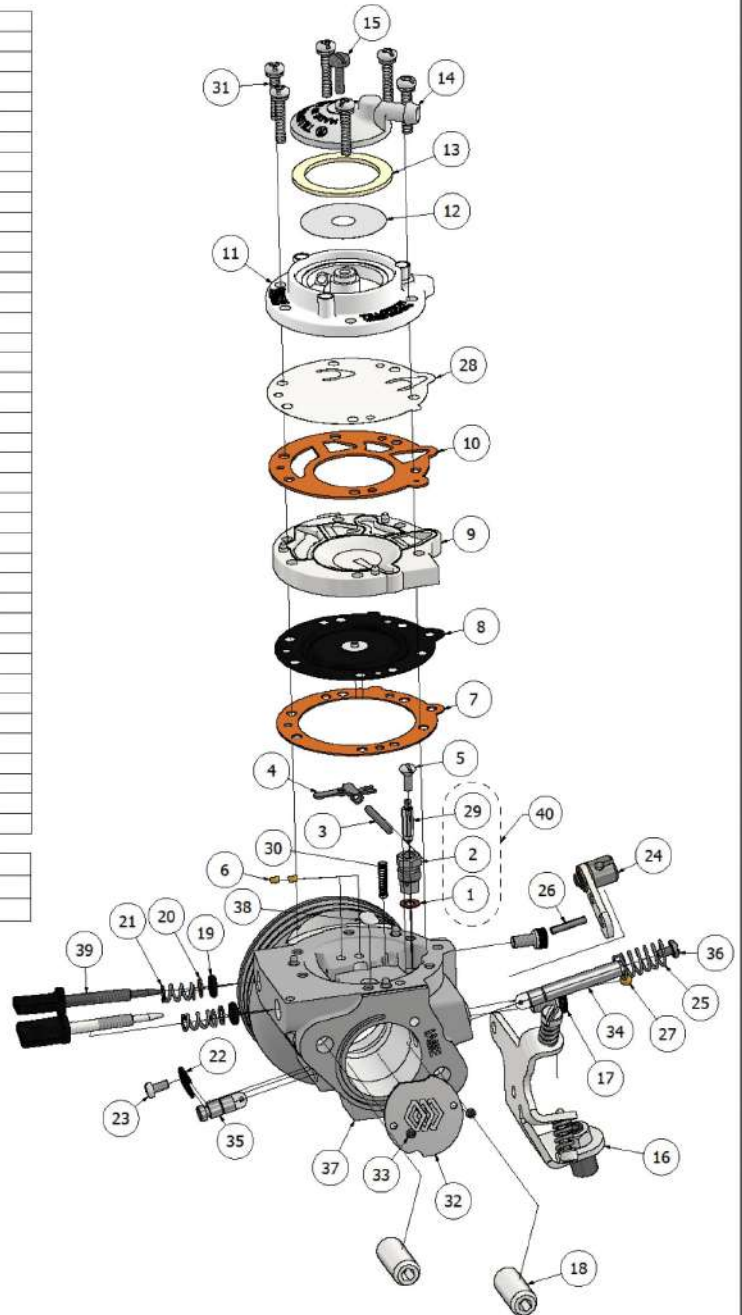
PARTS LIST			
ITEM	QTY	PART NUMBER	DESCRIPTION
1	1	16-B199	* COPPER GASKET, INLET SEAT
2	1	36-A42	* INLET SEAT
3	1	32-79	FULCRUM LEVER PIN
4	1	155-A27	* INLET VALVE CONTROL LEVER
5	1	15-B329	FULCRUM LEVER SCREW
6	2	80-160	BRASS PLUG
7	1	16-B406	*+ DIAPHRAGM GASKET (ORANGE)
8	1	237-600	*+ DIAPHRAGM ASSEMBLY
9	1	91-A275	DIAPHRAGM COVER
10	1	16-B407	*+ FUEL PUMP GASKET (ORANGE)
11	1	141-89	PUMP COVER
12	1	95-170	* FUEL STRAINER SCREEN
13	1	16-B205	*+ STRAINER GASKET
14	1	91-A251	WHITE STRAINER COVER
15	1	15-B313	COVER SCREW
16	1	136-562	CABLE BRACKET ASSEMBLY
17	2	15-C67	M4 X 0.7 SOCKET CAP SCREW
18	2	81-377	CARBURETTOR MOUNTING NUT
19	2	44-361	ADJUSTMENT SCREW O-RING
20	2	78-A256	ADJUSTMENT SCREW WASHER
21	2	24-B449	ADJUSTMENT SCREW SPRING
22	1	29-224	THROTTLE SHAFT CLIP
23	1	15-C19	4-40 UNC SCREW
24	1	12-1220	THROTTLE LEVER ASSEMBLY
25	1	24-B381	THROTTLE RETURN SPRING
26	1	62-A92	PIN
27	1	206-135	4MM BRASS BALL
28	1	237-223	*+ FUEL PUMP DIAPHRAGM
29	1	34-216	* INLET NEEDLE
30	1	24-C298	INLET TENSION SPRING 42g
31	6	15-C51	6 - 32 UNC SCREW
32	1	14-A140	THROTTLE SHUTTER
33	2	15-C105	M2 X .4 SCREW
34	1	13-B220B	SPLIT THROTTLE SHAFT LONG
35	1	13-B220A	SPLIT THROTTLE SHAFT SHORT
36	1	15-C52	LEVER SCREW
37	1	219-D333TL	HW MACHINED BODY
38	1	179-69	WELCH PLUG
39	2	43-1035	IDLE MIXTURE SCREW

40	1	233-721P	INLET SEAT & NEEDLE ASSEMBLY PACK
	1	DG-10HW	DIAPHRAGM& GASKEY KIT
	1	RK-14HW	REPAIR KIT

**NOTES:**

\* INDICATES CONTENTS OF REPAIR KIT

\*+ INDICATES CONTENTS OF DIAPHRAGM & GASKET KIT

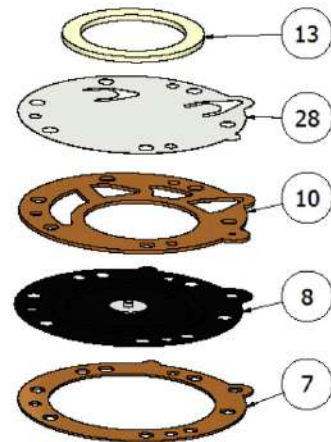




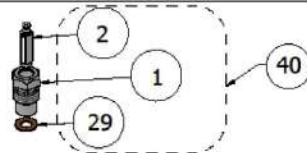
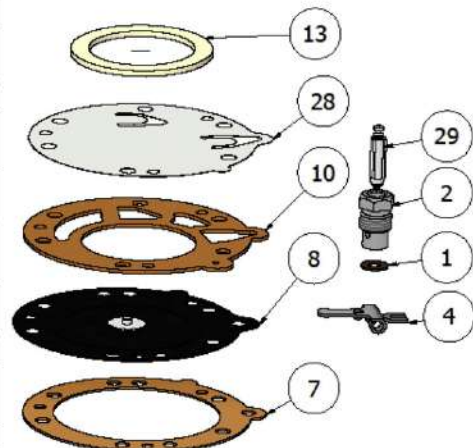
## CARBURETTOR DESCRIPTION AND SKETCH OF PARTS CARBURATEUR - DESCRIPTION ET DESSIN DES PIÈCES

### HW-50A REPAIR KIT EXPLODED VIEW

DIAPHRAGM & GASKET KIT [DG-10HW]			
ITEM	QTY	PART NUMBER	DESCRIPTION
7	1	16-B406	*+ DIAPHRAGM GASKET (ORANGE)
8	1	237-600	*+ DIAPHRAGM ASSEMBLY
10	1	16-B407	*+ FUEL PUMP GASKET (ORANGE)
13	1	16-B205	*+ STRAINER GASKET
28	1	237-223	*+ FUEL PUMP DIAPHRAGM



REPAIR KIT [RK-14HW]			
ITEM	QTY	PART NUMBER	DESCRIPTION
1	1	16-B199	* COPPER GASKET, INLET SEAT
2	1	36-A42	* INLET SEAT
4	1	155-A27	* INLET VALVE CONTROL LEVER
7	1	16-B406	*+ DIAPHRAGM GASKET (ORANGE)
8	1	237-600	*+ DIAPHRAGM ASSEMBLY
10	1	16-B407	*+ FUEL PUMP GASKET (ORANGE)
13	1	16-B205	*+ STRAINER GASKET
28	1	237-223	*+ FUEL PUMP DIAPHRAGM
29	1	34-216	* INLET NEEDLE



40 -INLET SEAT AND NEEDLE ASSEMBLY PACK [233-721P]			
ITEM	QTY	PART NUMBER	DESCRIPTION
1	1	36-A42	* INLET SEAT
2	1	34-216	* INLET NEEDLE
29	1	16-B199	* COPPER GASKET, INLET SEAT



PARTS OF CARBURETTOR - PIÈCES DU CARBURATEUR

REF.7 - P. N°16-B406  
DIAPHRAGM GASKET (ORANGE COLOR)  
JOINT DE DIAPHRAGME (COULEUR ORANGE)



Thickness / Épaisseur =  $0.5 \pm 0.1$  mm

REF.10 - P. N° 16-B407  
PUMP DIAPHRAGM GASKET (ORANGE COLOR)  
JOINT DE POMPE À ESSENCE (COULEUR ORANGE)



Thickness / Épaisseur =  $0.8 \pm 0.1$  mm

REF.8 - P. N°237-600  
DIAPHRAGM / DIAPHRAGME



Thickness / Épaisseur =  $0.13 \pm 0.07$  mm

REF.28 - P. N°237-223  
PUMP DIAPHRAGM (TRASPARENT)  
MEMBRANE DE POMPE À ESSENCE



Thickness / Épaisseur =  $0.07 \pm 0.0127$  mm

REF.9 - P. N° 91-A275  
DIAPHRAGM COVER / COUVERCLE DE DIAPHRAGME



Thickness / Épaisseur =  $6.75 \pm 0.15$  mm

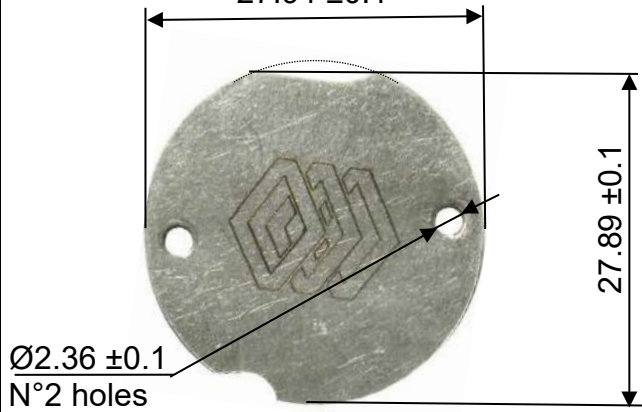
REF.11 - P. N° 141-89  
PUMP COVER / CORPS DE POMPE À ESSENCE



Thickness / Épaisseur =  $12.5 \pm 0.15$  mm

REF.32 - P. N° 14-A140  
THROTTLE SHUTTER  
PAPILLON

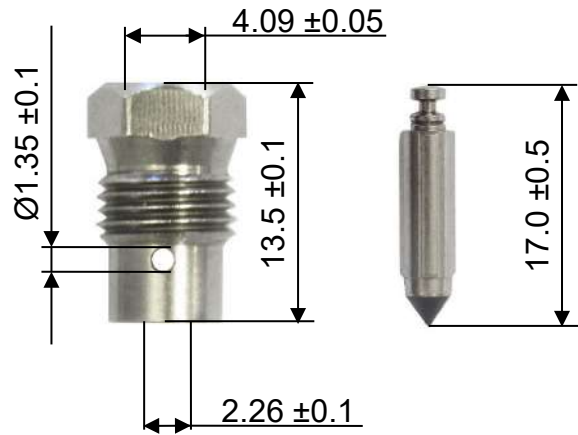
27.94 ±0.1



Ø2.36 ±0.1  
N°2 holes

Thickness / Épaisseur = 0.81 ±0.1 mm

REF. 1,2 and 29 (KIT REF. 40) - P. N° 233-721P  
SEAT + NEEDLE  
SIEGE + POINTEAU



REF.39 - P. N° 43-1035  
NEEDLE LOW SPEED  
VIS DE RÉGLAGE BAS-REGIME

52.50 ±0.50



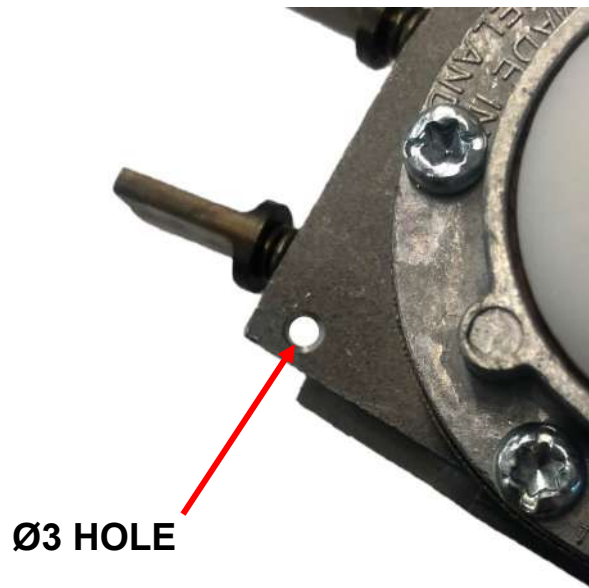
REF.39 - P. N° 43-1035  
NEEDLE HIGH SPEED  
VIS DE RÉGLAGE HAUT-REGIME

52.50 ±0.50



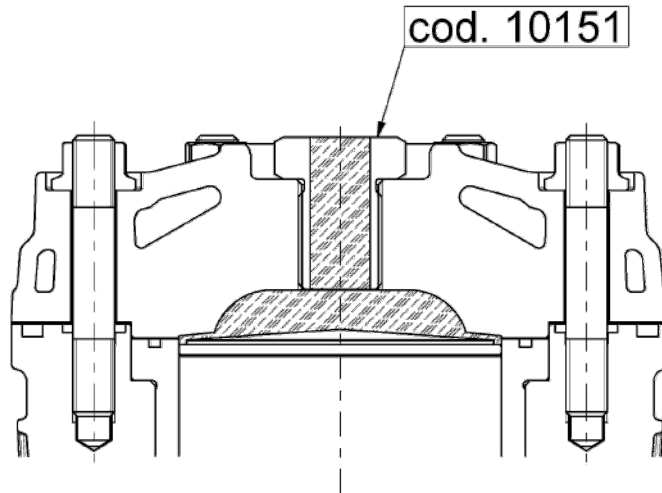
HOLE FOR CARBURETTOR SEALING  
TROU POUR LE PLOMBAGE

The carburettor can have this hole for sealing.  
*Le carburateur peut avoir ce trou pour le plombage.*

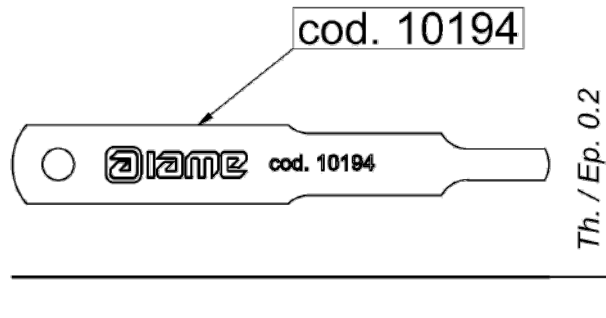


CHECKING TOOLS - OUTILS DE CONTROLE

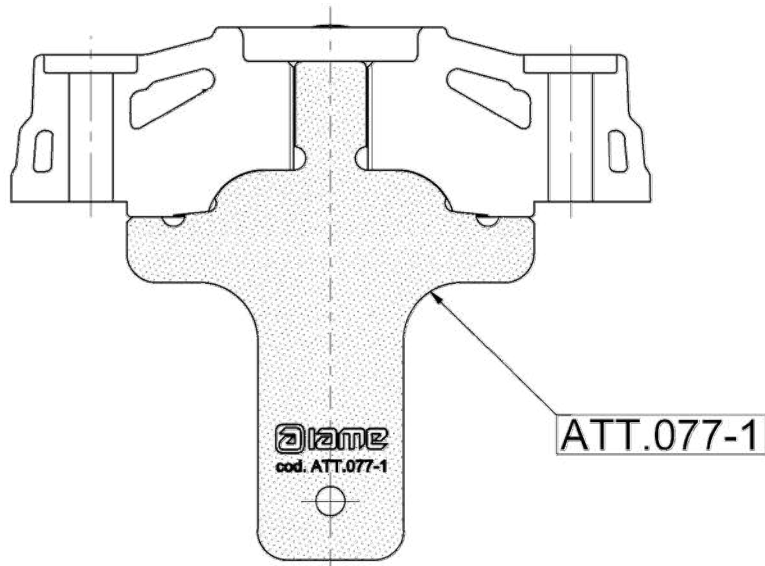
INSERT FOR COMBUSTION CHAMBER VOLUME  
*INSERT POUR LE VOLUME DE LA CHAMBRE DE COMBUSTION*



WEDGE FOR PORT TIMING  
*CALE POUR LECTURE DES ANGLES DE DISTRIBUTION*

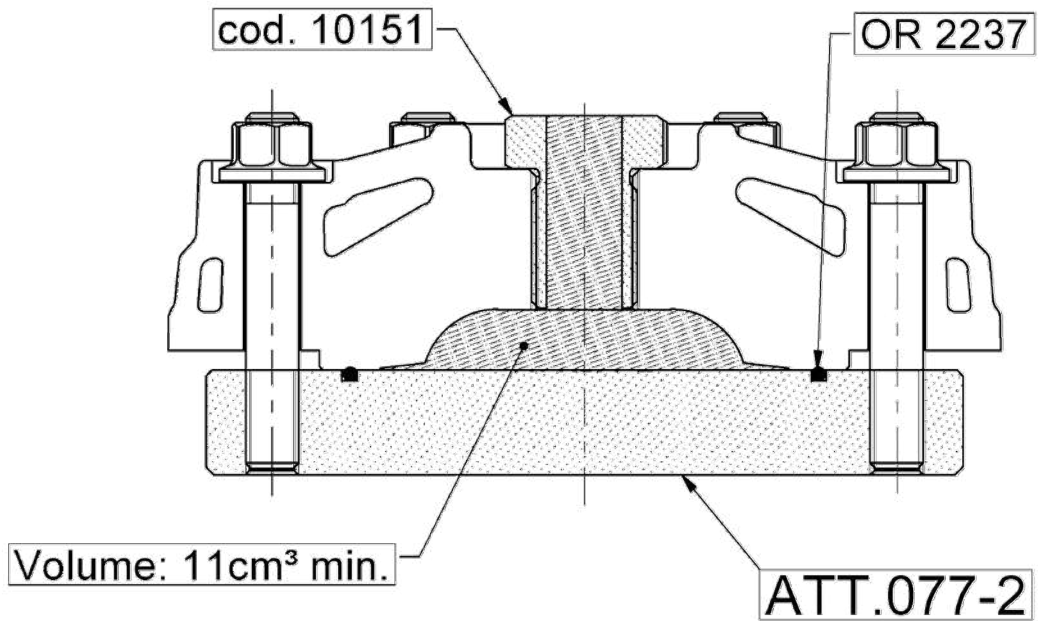


TEMPLATE FOR COMBUSTION CHAMBER SHAPE  
*GABARIT POUR LA FORME DE LA CHAMBRE DE COMBUSTION*

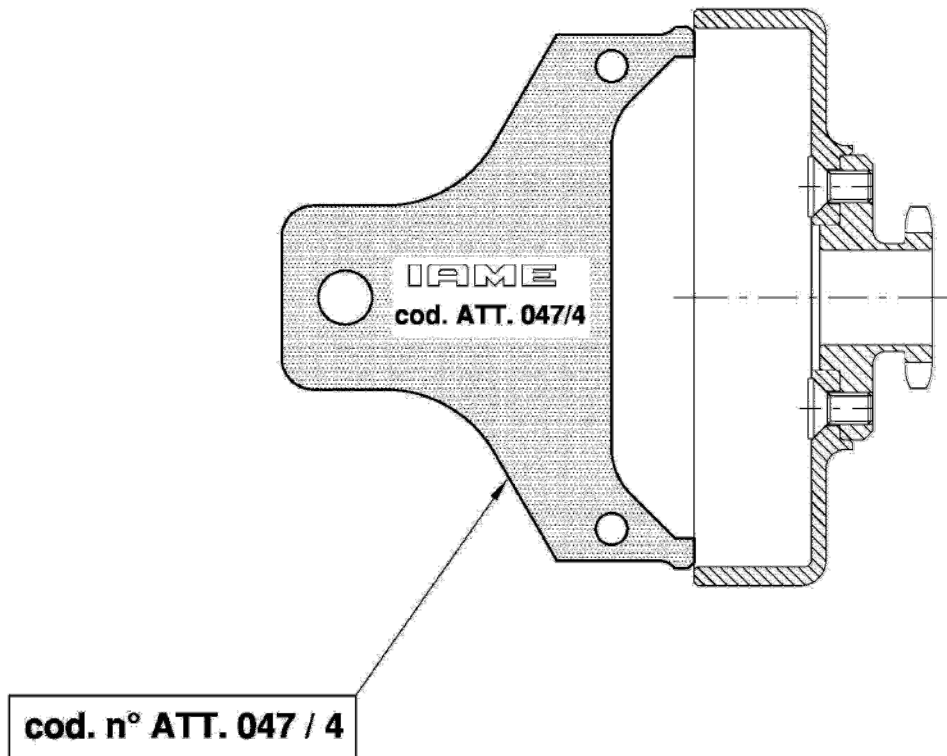




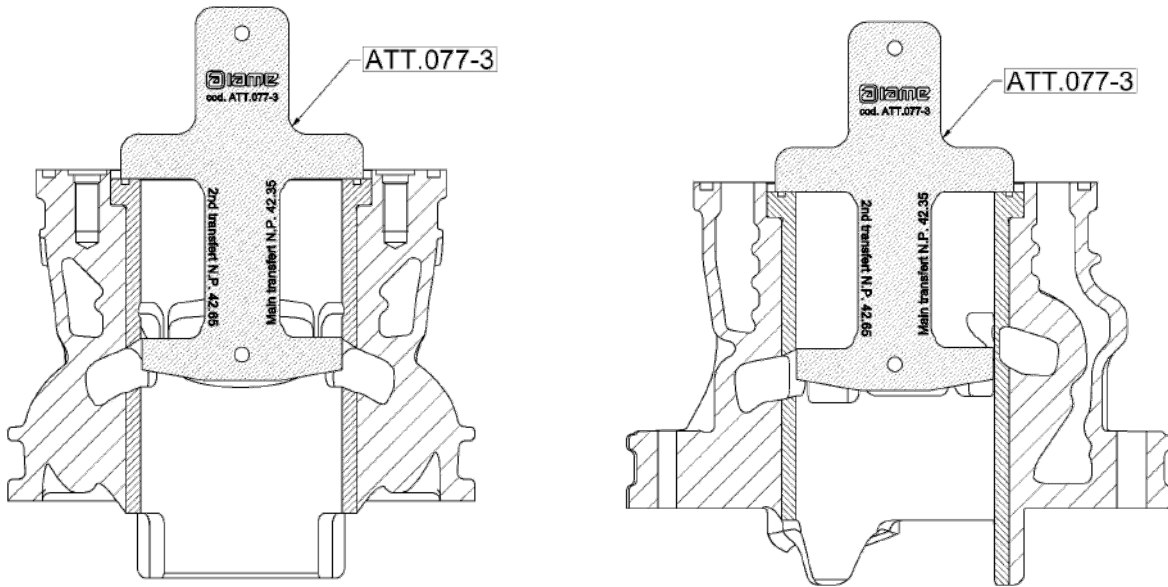
TOOL FOR THE VOLUME IN THE CYLINDER HEAD  
OUTIL POUR LE VOLUME DANS LA CULASSE



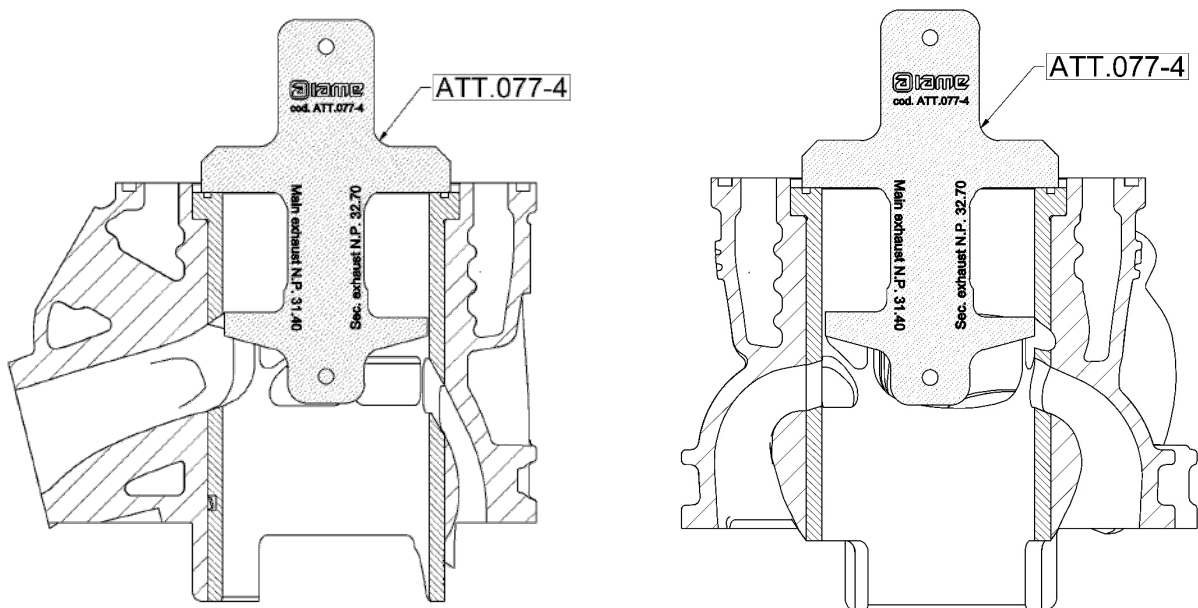
NO-GO GAUGE FOR CLUTCH DRUM  
GABARIT POUR LA CLOCHE D'EMBAYAGE



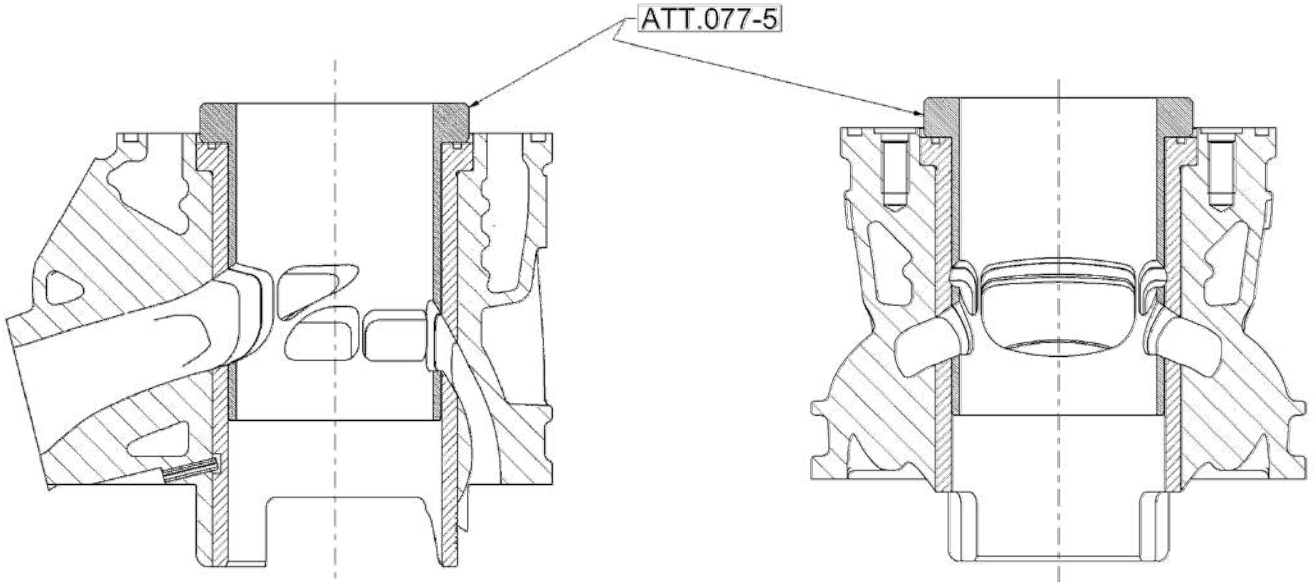
**NO GO GAUGE FOR THE HEIGHT OF MAIN AND SECONDARY TRANSFERS**  
**GABARIT POUR LA HAUTEUR DES TRANSFERTS PRINCIPAUX ET SECONDAIRES**



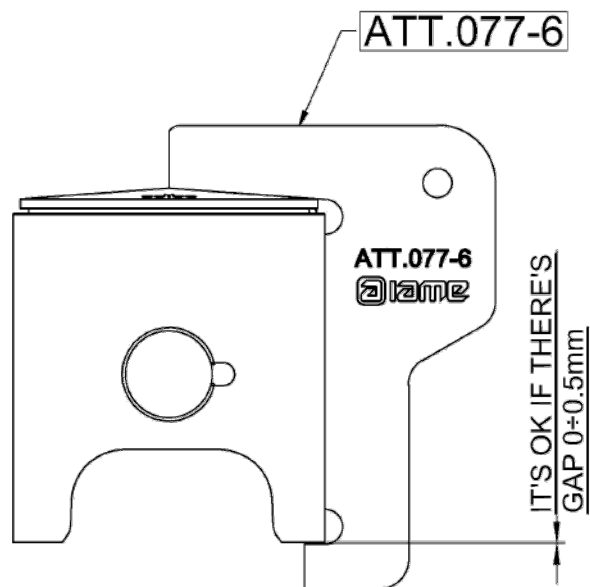
**NO GO GAUGE FOR EXHAUST MAIN DUCT AND BOOSTERS**  
**GABARIT POUR LA HAUTEUR DE LA LUMIERE D'ÉCHAPPEMENT ET DES BOOSTERS**



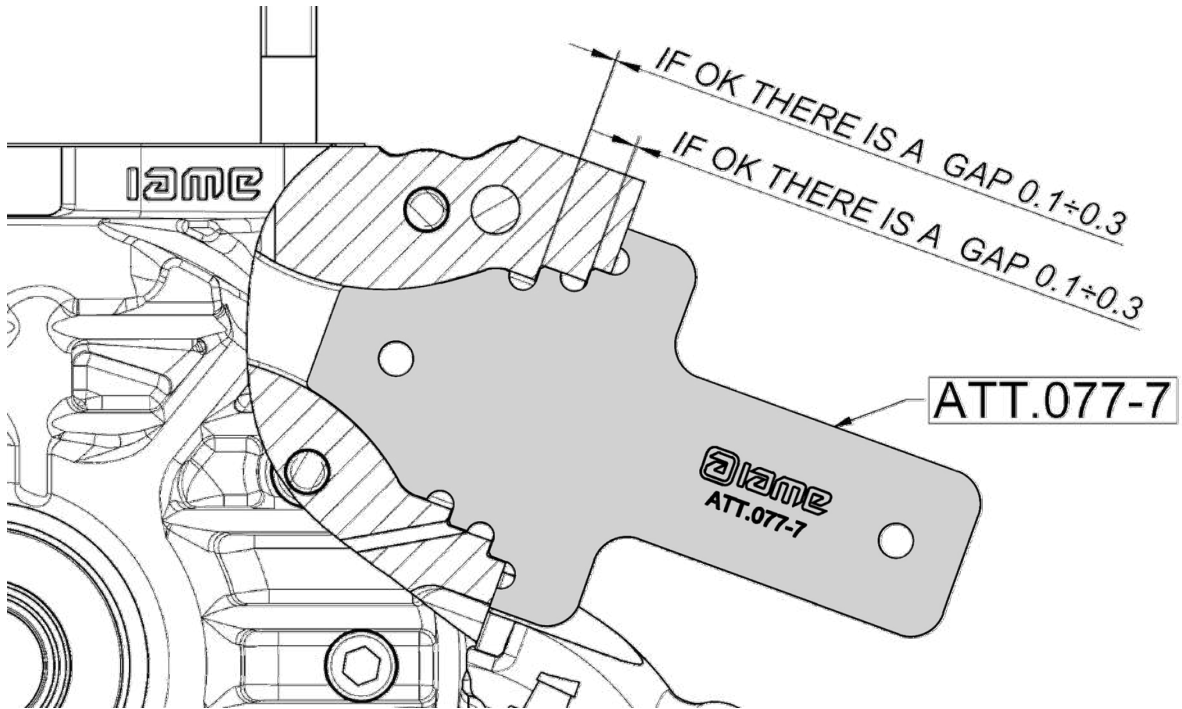
DUMMY LINER FOR PORTS CHECKING  
FAUSSE-CHEMISE POUR LA VÉRIFICATION DES LUMIÈRES



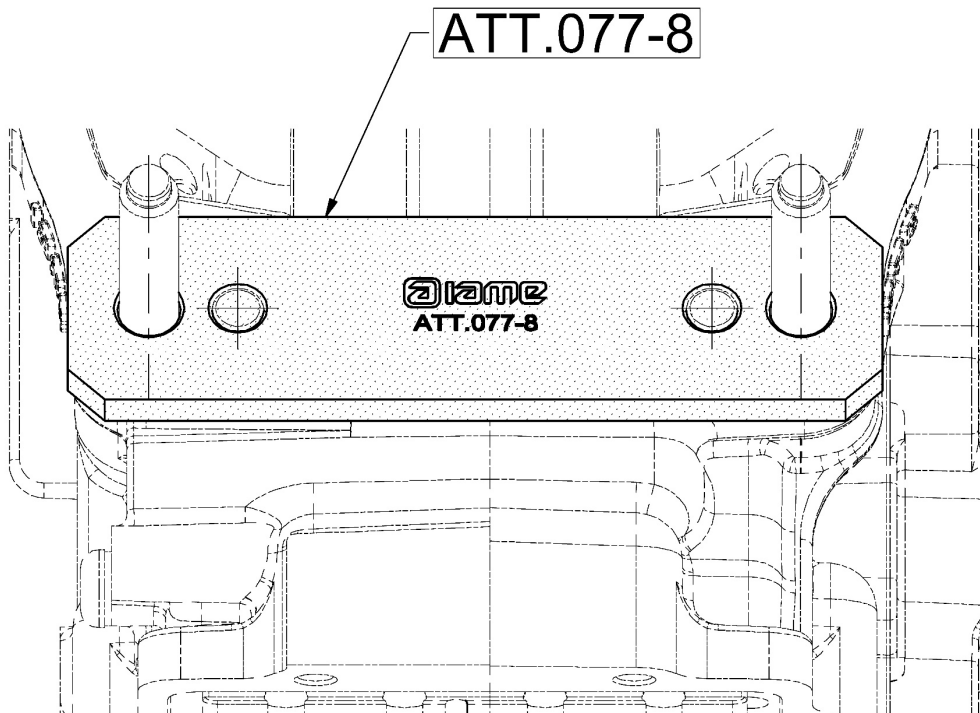
TEMPLATE FOR PISTON DOME AND HEIGHT  
GABARIT POUR LE DOME ET LA HAUTEUR DU PISTON



TEMPLATE FOR REED VALVE SEAT AND PLANE  
GABARIT POUR LE PLAN ET LOGEMENT DE LA BÔTE À CLAPETS



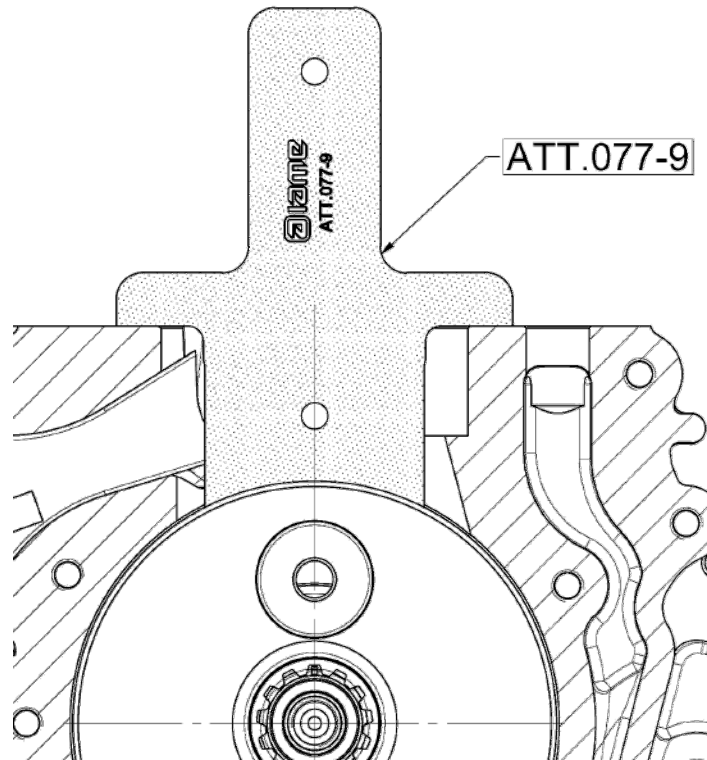
TEMPLATE FOR THE CILYNDER PINS INTERAXLE  
GABARIT POUR L'ENTRAXE DES PIONS DE CENTRAGE DU CYLINDRE



CHECKING TOOLS - OUTILS DE CONTROLE

GAUGE FOR THE CYLINDER PLANE ON THE CRANKCASE

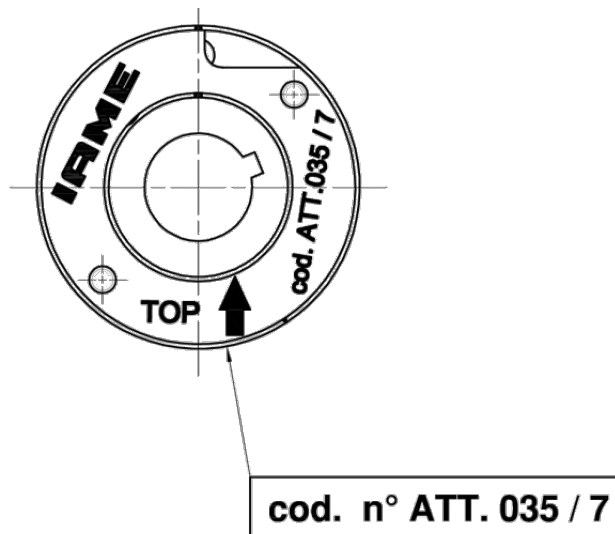
*It must touch the plane before touching the crankshaft*  
**GABARIT POUR LA HAUTEUR DU PLAN CYLINDRE SUR LE CARTER**  
*il doit toucher le plan avant de toucher le vilebrequin*



TEMPLATE FOR THE MARKING POSITION ON SELETTRA DIGITAL "S" ROTOR

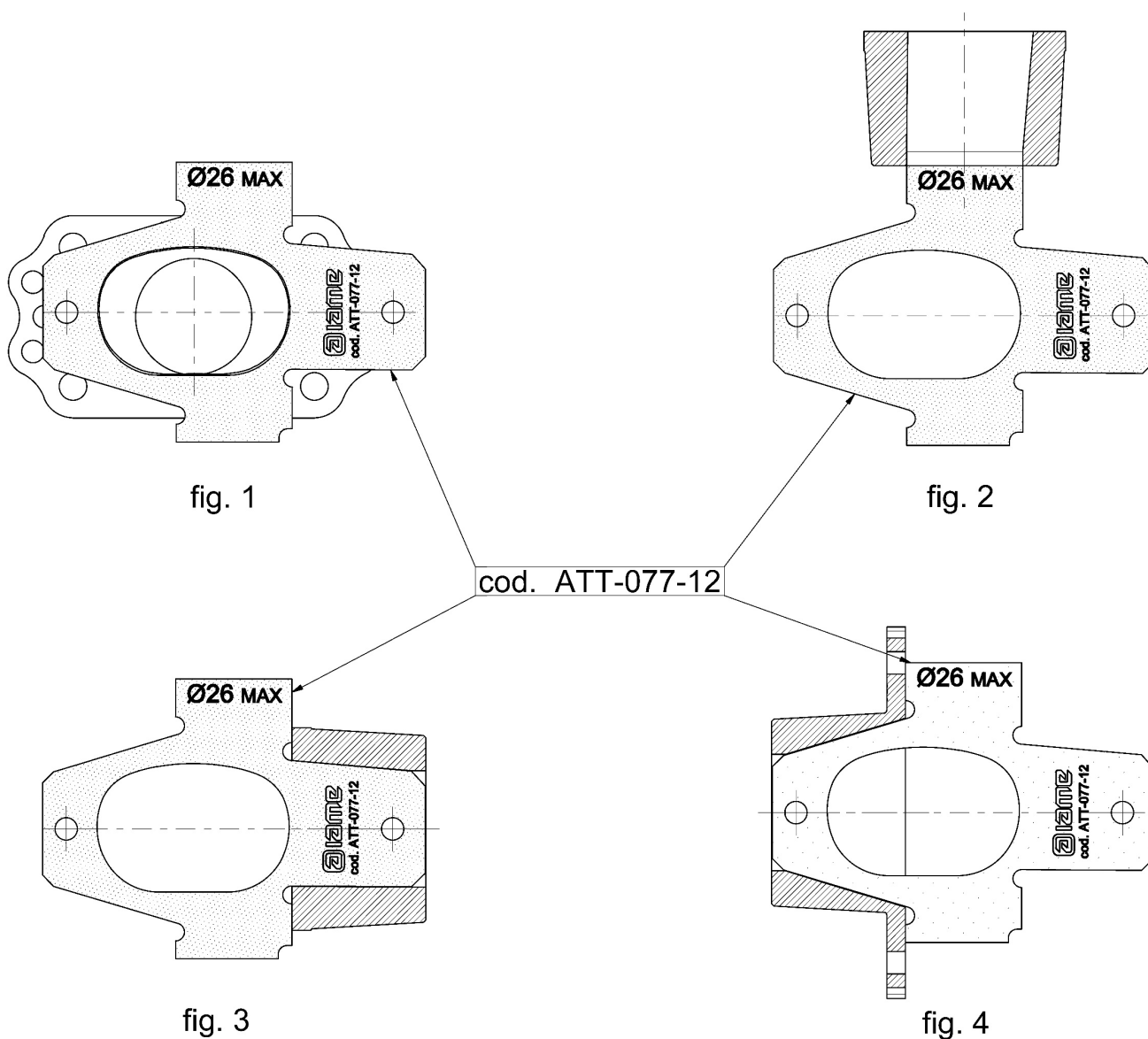
OK when the marking is hidden by the template

**GABARIT POUR LE MARQUAGE DE PHASE SUR LE ROTOR SELETTRA DIGITAL "S"**  
*OK si le marquage est couvert par le gabarit*





EXHAUST MANIFOLD CHECKING TOOL - CONTRÔLE DU RACCORD D'ÉCHAPPEMENT

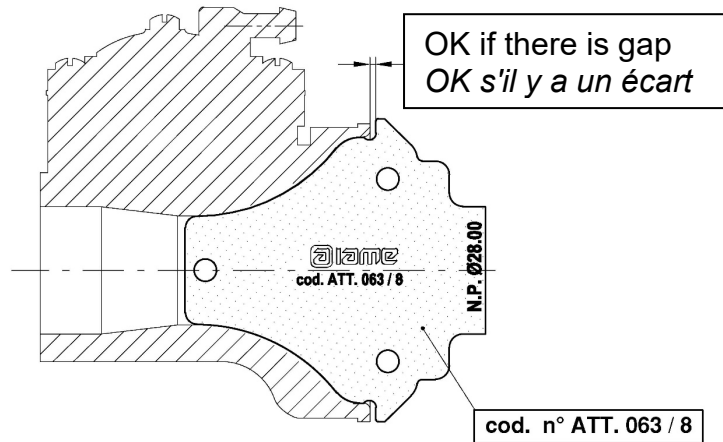


THE NO-GO GAUGE MUST NOT ENTER INTO THE EXHAUST RESTRICTOR, (FIG.2);  
VERIFIEZ QUE LE CALIBRE N'ENTRE PAS DANS LE TROU DU RESTRICTEUR D'ÉCHAPPEMENT.

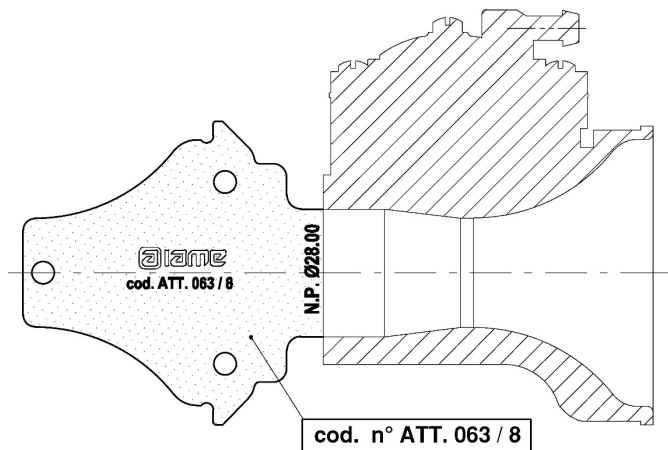
CHECK THAT THE TOOL MATCHES THE SHAPE OF THE EXHAUST MANIFOLD, (FIG.1,3 AND 4).  
VERIFIEZ QUE LA FORME DU RESTRICTEUR D'ÉCHAPPEMENT EST LA MEME QUE L'OUTIL

CHECKING TOOLS - OUTILS DE CONTROLE

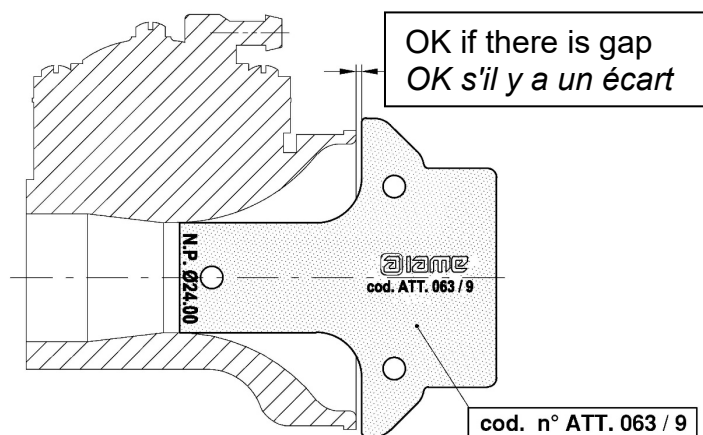
**TEMPLATES FOR TILLOTSON HW-50A**  
**GABARITS POUR LE CARBURATEUR TILLOTSON HW-50A**



**THE CARBURETTOR DUCT MUST HAVE THE SAME SHAPE AS THE TEMPLATE**  
**LE VENTURI DU CARBURATEUR DOIT COMPLETEMENT EPOUSER LA FORME DU GABARIT**

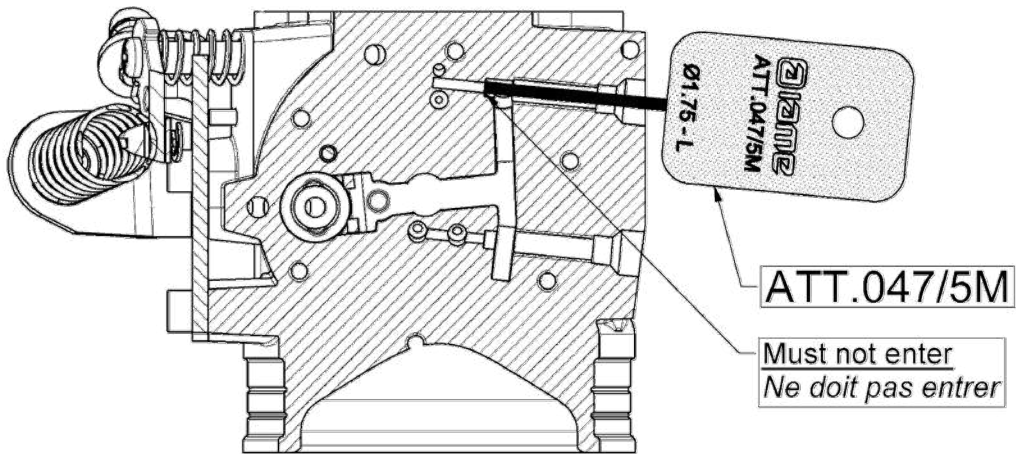


**THE GAUGE MUST NOT ENTER THE THROTTLE BORE**  
**LE GABARIT NE DOIT PAS ENTRER DANS L'ALEPAGE DU PAPILLON**

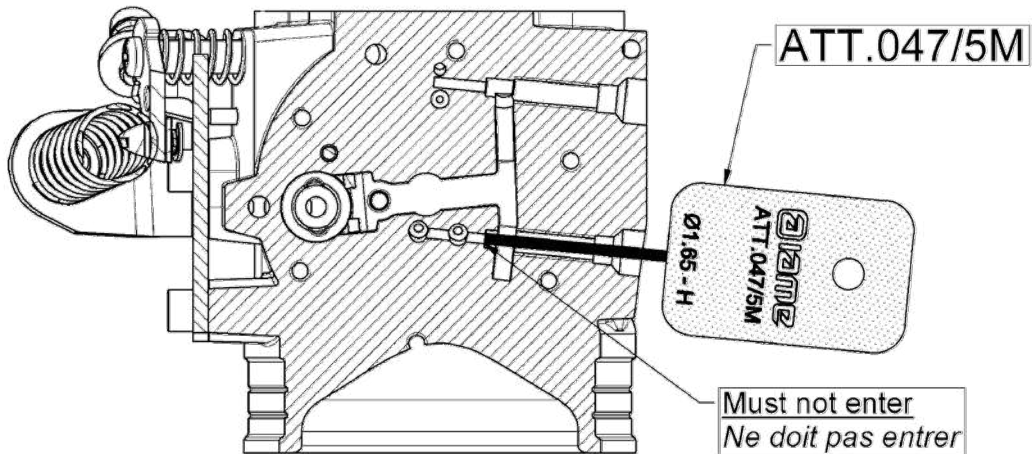


**THE GAUGE MUST NOT ENTER INTO THE VENTURI**  
**LE GABARIT NE DOIT PAS ENTRER DANS LE VENTURI**

HOLES JET SCREWS "NO-GO" CHECKING TOOL  
OUTIL POUR LE CONTRÔLE DES TROUS DE VIS



CHECK THAT THE SPIKES DO NOT ENTER INTO THE HOLES.  
VERIFIEZ QUE LES POINTES N'ENTRE PAS DANS LES TROUS



**ATOMIZER HOLES CHECKING TOOL**  
**OUTIL POUR LE CONTRÔLE DES TROUS DU PULVERISATEUR**

